

Instruments of the Orchestra

Photocopiable Factsheets & Worksheets
on the String Section

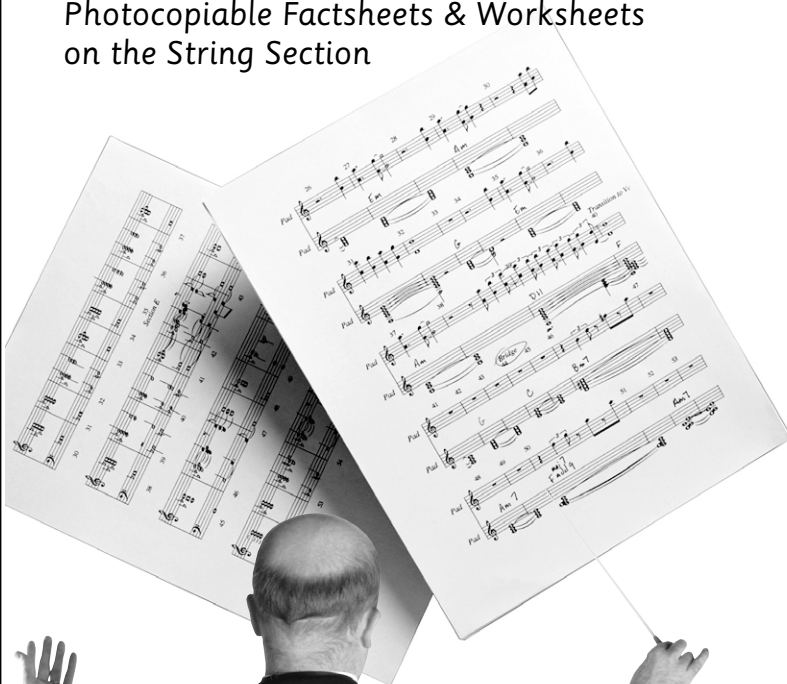

INTRODUCTION TO THE ORCHESTRA - Factsheet

An orchestra is a group of musicians who play together. The main difference between an orchestra and a band is that an orchestra contains stringed instruments as well as brass, woodwind and percussion.

There are several types of orchestra:

- a string orchestra, which as the name suggests contains only stringed instruments
- a dance orchestra, which has a small string section but is mainly woodwind and percussion instruments
- a symphony orchestra which usually has a large string section as well as brass, woodwind and percussion sections.

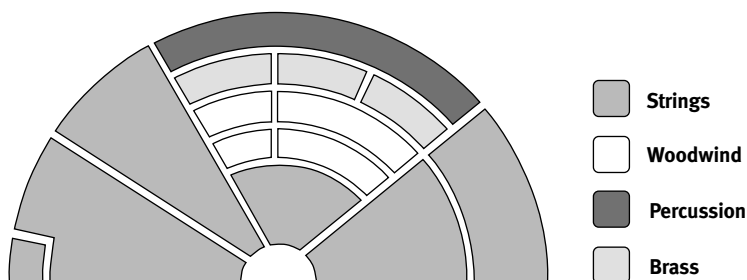

Sections of the Symphony Orchestra

In a symphony orchestra the instruments are divided up into four main sections or groups.

- Strings
- Woodwind
- Brass
- Percussion

The size of an orchestra can vary enormously from a small chamber orchestra which has between 15 and 40 players and a full symphony orchestra which can have as many as 100 people.

THE SCORE & THE ROLE OF THE CONDUCTOR

Orchestral music is written out on a score. A full score is used by the conductor and shows all the music for all the instruments together. Each instrument will then have a copy of the music of their part rather than having to follow a score with all the instruments on it. In full scores the instruments are usually grouped together by section so that it is easier for the conductor to follow.

The violin section of the orchestra is usually divided up into two groups: 1st violins and 2nd violins. The leader of the orchestra is the leader of the 1st violin section and sits at the front to assist the conductor. Orchestras have steadily increased in size through the centuries and originally the leader of the violins would have also directed the orchestra and there wouldn't have been a conductor. As orchestras grew in size it became difficult to play and conduct so a separate conductor began to direct the orchestra.

It is the conductor's job to make sure that the musicians keep time with one another and to help with the interpretation and performance of a piece. This may include the tempo (speed), dynamics (whether the music should be loud or soft) and phrasing. Often the conductor will choose the music that is to be performed and even help to audition the musicians.

Symphonie Nr. 10
Dmitri Schostakowitsch, op. 93
Dmitri Shostakovich, Op. 93

Moderato *Allegro* I

Name: _____

INTRODUCTION TO THE ORCHESTRA - Worksheet

The modern day orchestral plan is shown below. Try and place the instruments in the correct places. In following lessons we will learn more about each instrument.

HORNS

OBOES

CELLOS

TIMPANI

CLARINETS

TROMBONES

TRUMPETS

VIOLAS

1st VIOLINS

FLUTES

2nd VIOLINS

PERCUSSION

HARP

DOUBLE BASSES

BASSOONS

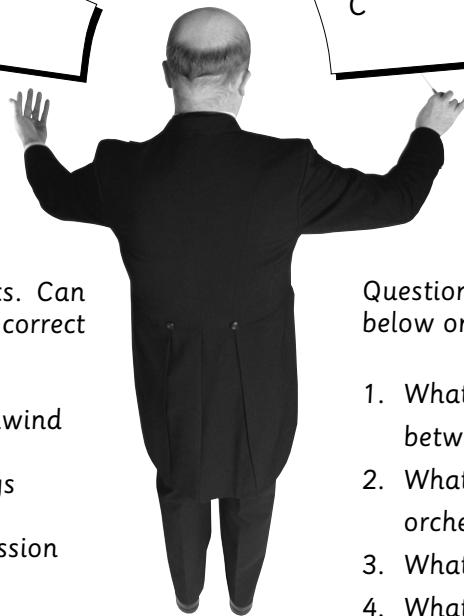
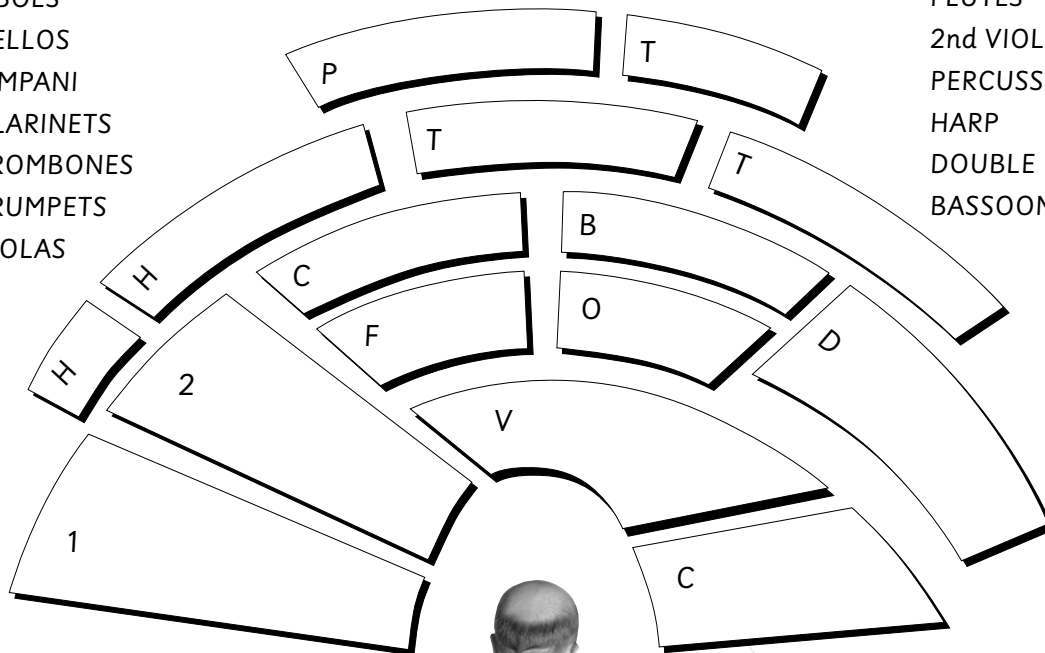

Here are several instruments. Can you match them up with their correct section?

Violin

Woodwind

Tuba

Strings

Double Bass

Percussion

Piccolo

Brass

Clarinet

Strings

Marimba

Woodwind

Timpani

Brass

Trombone

Percussion

Question Time! Answer the questions below on a separate sheet.

1. What is the main difference between an orchestra and a band?
2. What is the largest section of the orchestra?
3. What is a full score?
4. What are dynamics?
5. Who uses a full score and why?
6. Where would you find the leader of the orchestra?
7. Why did orchestras begin to be directed by a conductor?
8. What does the word tempo relate to?

Name: _____

THE VIOLIN - Factsheet

The violin is the smallest member of the string family found in an orchestra. The earliest violins were made in Italy around 1550 and developed from the medieval fiddle and rebec.

The bow is a stick with horsehair stretched tightly across it. As the bow is drawn across the strings it makes them vibrate and so sound is produced. The modern bow is called a tourte bow after François Tourte who invented it. The pitch of the notes is altered as the violinist presses down on the strings along the fingerboard at the same time as drawing the bow across the strings. Shortening the strings produces higher notes.

If you see the word *pizzicato* (pizz.) written on music it indicates that the performer should pluck the strings rather than play using the bow. When the bow is needed again you will see the word *arco* written in the music.

A mute looks rather like a three-pronged comb that is fitted over the bridge. It limits the vibrations of the strings and so softens the sound of the instrument. If a string player is asked to play *con sordino* this means play using the mute.

The most famous makers of the violin were Stradivari and Guarneri and their instruments command very high prices today.

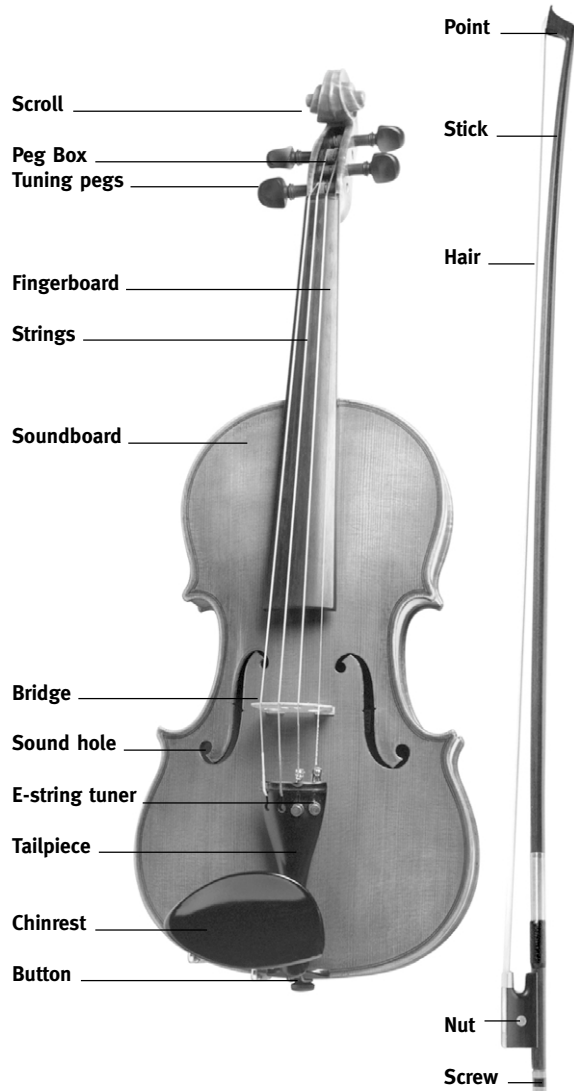

Famous works for violin:

Six Solo Partitas	J.S.Bach
Four Seasons Concertos	Vivaldi
Haffner Serenade	Mozart
Violin Concerto in D Major	Beethoven
Sonata in G Major	Brahms

In a string quartet there are usually two violins. The folk violin is sometimes known as the fiddle.

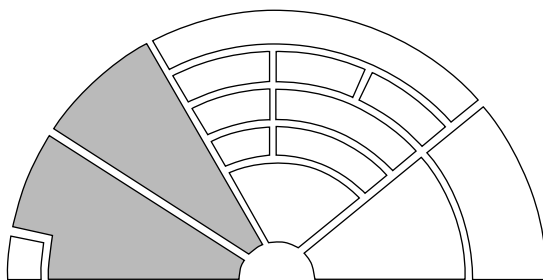

Orchestral position

Violin pitch range

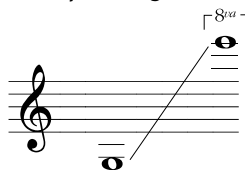

Famous violinists:

Niccolo Paganini
Yehudi Menuhin
Vanessa Mae
Nigel Kennedy

Name: _____

THE VIOLIN - Worksheet

Label the diagrams and then try to find the words associated with the violin in the wordsearch.

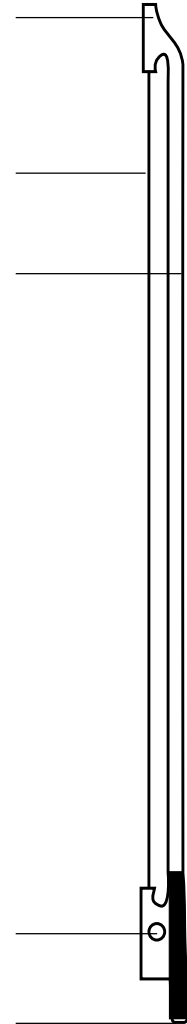
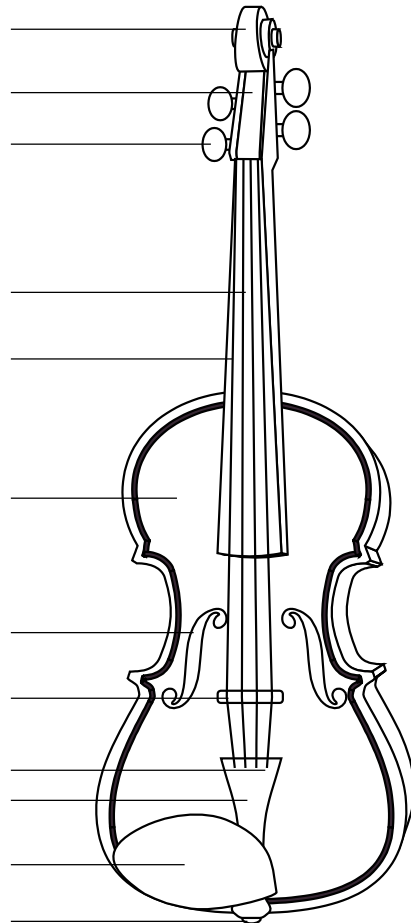

S	T	R	A	D	I	V	A	R	I	Y	B	P
B	E	M	N	A	G	A	B	J	Z	S	R	I
D	C	M	E	N	U	H	I	N	F	G	I	Z
E	M	I	C	W	E	L	M	K	W	N	D	Z
H	D	M	K	C	V	I	U	M	J	I	G	I
A	P	E	R	J	H	N	T	U	C	R	E	C
T	U	N	I	N	G	P	E	G	S	T	E	A
F	O	U	R	S	E	A	S	O	N	S	I	T
S	B	O	W	T	S	E	B	A	S	S	T	O

Bridge
 Neck
 Four Seasons
 Mute
 Stradivari
 Pizzicato
 Bow
 Menuhin
 Strings
 Tuning Pegs

Name: _____

THE VIOLA - Factsheet

The size of the viola can vary although it is always larger than the violin, usually around 7.5cm (3 inches) longer. However it is made in exactly the same way as the violin. Because of its extra size the viola has a more mellow sound than the violin and its pitch is lower. Early violas were rather large so few musicians could play it comfortably. As a result the viola was not very popular until the size became more manageable.

It wasn't until the eighteenth century that composers really began to explore the musical possibilities of this instrument. Some of the later string quartets by Haydn and Mozart were the first examples of the viola having a prominent part to play. Before this time the viola usually doubled the cello part. In a string quartet there is one viola.

Music for the viola is written in the alto clef except for very high notes which are written in the treble clef. The alto clef looks like this:



In the alto clef middle C is found on the middle line.

Famous works for viola:

Brandenburg Concerto No.6	J.S.Bach
Symphony No.10 (opening)	Mahler
Sinfonia Concertante	Mozart
Harold in Italy	Berlioz
Sonata in D Minor	Glinka

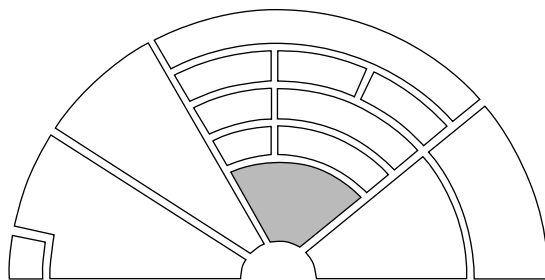
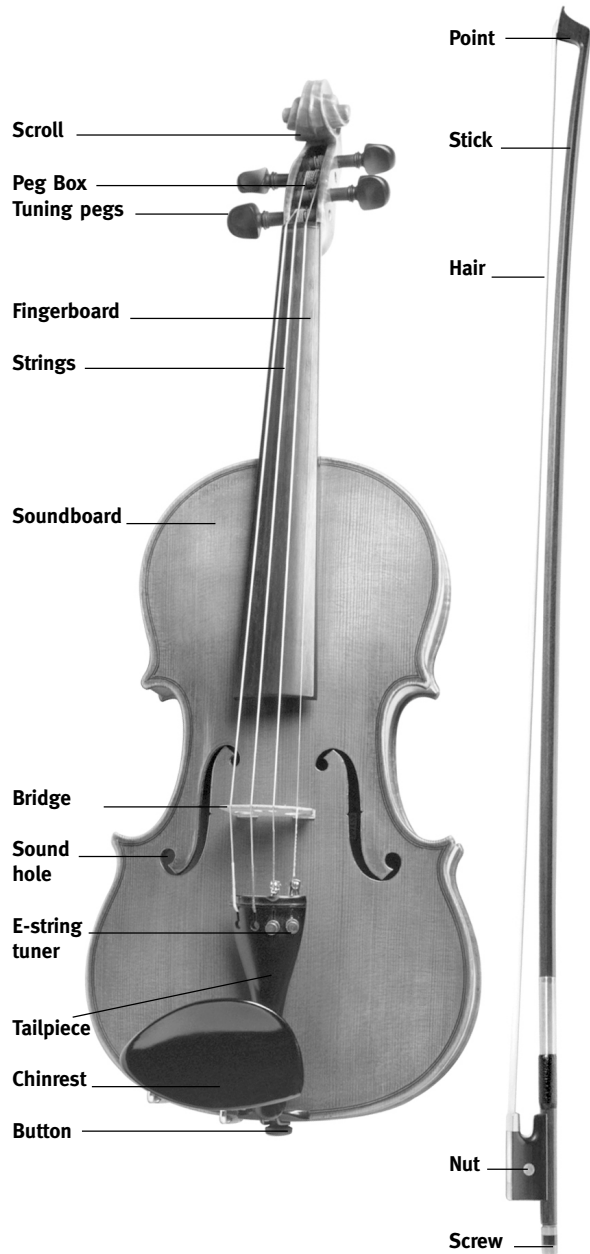

Orchestral position

Viola pitch range

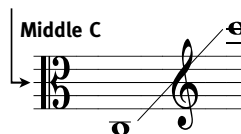

Famous viola players:

William Primrose
Yuri Bashmet
Lionel Tertis
Paul Hindemith

Name: _____

THE VIOLA - Worksheet

Fill in the other half of the diagram of the viola and the bow and see how many parts of the instrument you can name.

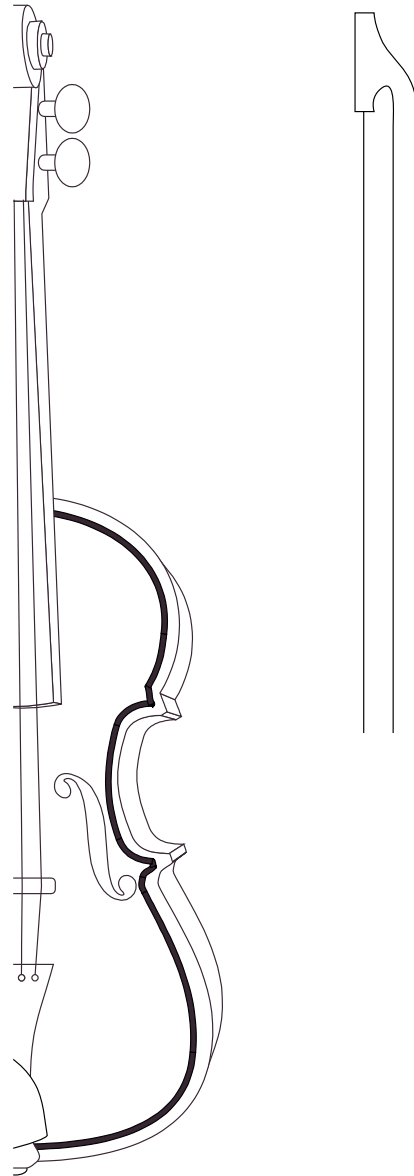

Here are ten statements about the viola. Answer true or false.

1. Yehudi Menuhin and Vanessa Mae are famous viola players? _____
2. The viola has four strings? _____
3. The viola is the highest member of the string family? _____
4. The violas are usually divided up into 1st violas and 2nd violas in the orchestra? _____
5. The viola was developed from the viola da gamba? _____
6. In a string quartet there is usually one viola? _____
7. The viola is sometimes called the fiddle? _____
8. Glinka wrote a Sonata in D Minor for the viola? _____
9. Music for the viola is mainly written in the alto clef? _____
10. The lowest note that can be played on the viola is the C below middle C? _____

Name: _____

THE CELLO - Factsheet

The cello or violoncello was first developed in the sixteenth century. For many years the viola da gamba which is a close relative of the cello was the more popular instrument. However, by the eighteenth century the cello had rapidly increased in popularity both as a solo instrument and as part of the orchestra. You can also find a cello in a string quartet.

The Baroque cello provided the bass line in both orchestral and smaller chamber pieces along with the harpsichord. This bass line playing is called continuo playing.

The cello uses a shorter and thicker bow than the violin or viola and is fitted with a retractable spike on the base of the instrument so that it can rest on the floor.

Cello music is written in the bass clef although sometimes the tenor or treble clef is used for very high notes. The tenor clef looks very similar to the alto clef but middle C is found on the fourth line and not the middle line.

Famous works for cello:

Six Suites for Solo Cello	J.S. Bach
Cello Concerto	Elgar
The Swan	Saint-Saens
Cello Concerto	Dvorak
Sonata for Cello & Orchestra	Penderecki

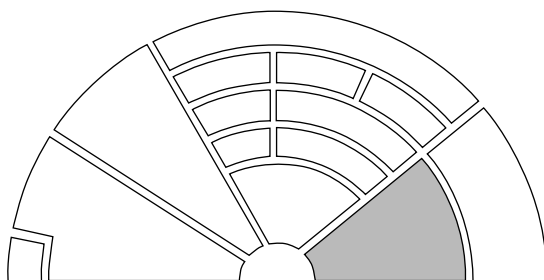
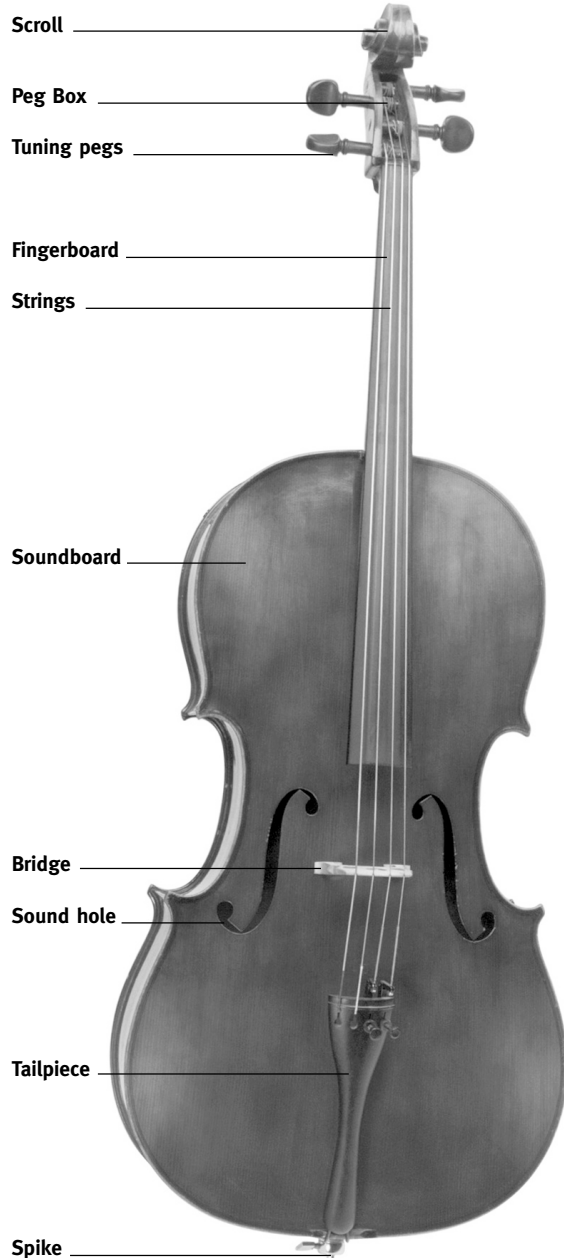

Orchestral position

Cello pitch range



Famous cellists:

Pablo Casals
Jacqueline DuPre
and Mstislav Rostropovich

Name: _____

THE CELLO - Worksheet

Label the diagram of the cello then fill in the missing words to complete the sentences below.

1. The cello has _____ strings.
2. The cello rests on a _____.
3. The full name for the cello is the _____.
4. The cello was developed in the _____.
5. The name given to someone who plays the cello is a _____.
6. _____ was an English composer who wrote a concerto for the cello which was made famous by Jacqueline DuPre.
7. In a string quartet the cello is the _____ instrument.
8. The cello is usually played with a _____ although the strings can be plucked.
9. If a performer is asked to play *con sordino* this means that they should play using the _____.
10. The cello uses the _____ clef.

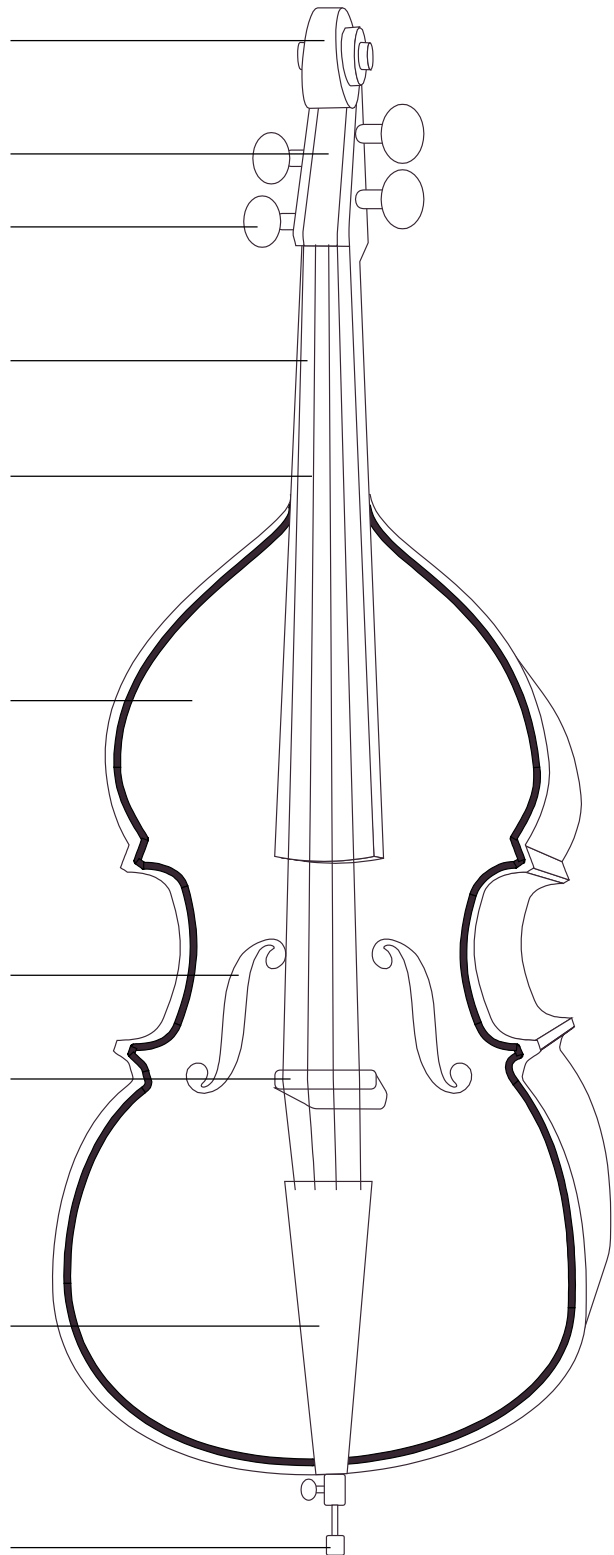

4	1500's	Elgar
Bass	Lowest	Mute
Spike	Cellist	Bow
Violoncello		

Name: _____

THE DOUBLE BASS - Factsheet

The double bass is the lowest sounding member of the orchestral string family. It was developed during the sixteenth century from the violone or double bass viol. Because of its size it was a difficult instrument to play and through the years several attempts have been made to make it easier to play.

There are two types of bow used with the double bass; a French bow which is held overhand like a violin bow and the Simandl bow which was named after its inventor and is held with the palm of the hand facing up.

The double bass is often used in jazz and dance bands as well as in the orchestra. The average size of the double bass is 1.8m high (around 6ft), so performers have to either stand or sit on a stool to play. Most double basses have four strings although some instruments have five strings.

Double bass music is usually written using the bass clef although it does occasionally use both the tenor and treble clef. It always sounds an octave lower than written.

Famous works for double bass:

Trout quintet for piano & strings	Schubert
Septet Op.20	Beethoven
Also sprach Zarathustra	Strauss
The Elephant	Saint-Saens

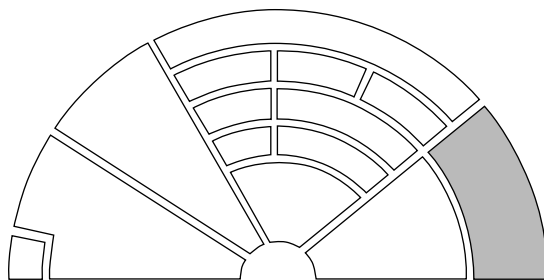
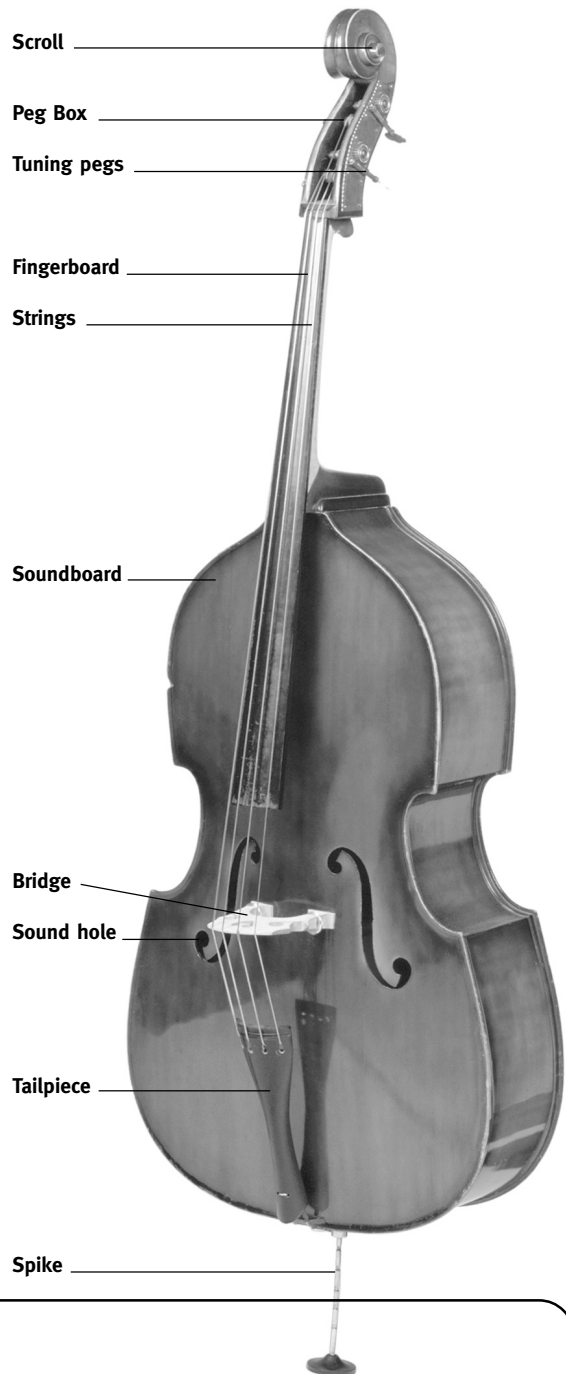

Double bass pitch range
(sounds one octave lower
than written)

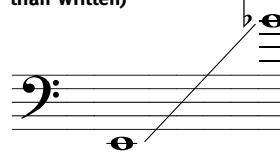

Famous double bassists

Charlie Mingus
Dominico Dragonetti
Stuart Knussen
Duncan McTier
Serge Koussevitsky

Name: _____

THE DOUBLE BASS - Worksheet

Use the outside of the codebreaker to help you find the name of a famous piece of music and its composer that is associated with the double bass.

BUODNKUT FM ECX UDNAUTR

ECX XTXJCUDE

BUANTTX RUNDE-RUXDR

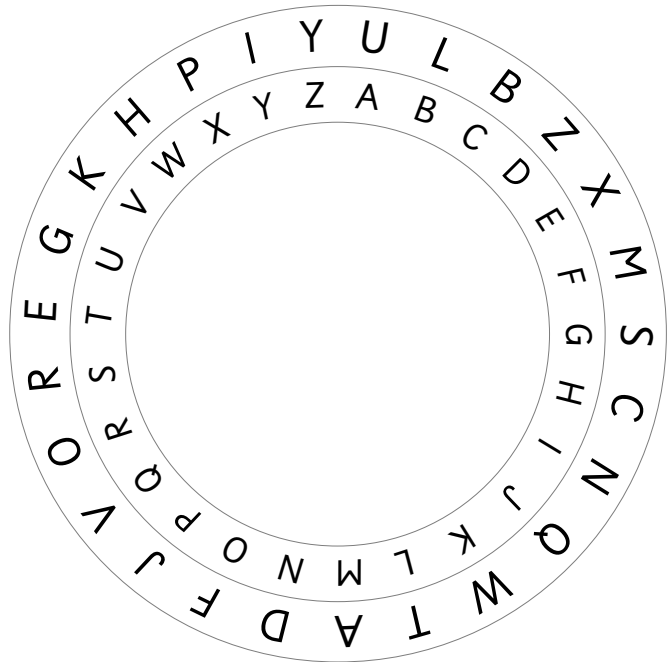

Fill in the missing word to complete the sentences below.

1. The double bass is the _____ member of the string section in an orchestra.
2. The double bass is often used in _____ music.
3. Double bass players usually _____ to play although sometimes they sit on a stool.
4. The double bass usually has _____ strings although sometimes it can have 5.
5. The double bass was developed in the _____ century.
6. The double bass developed from the older instrument the _____.
7. The double bass can be played using either a _____ bow or a _____ bow.
8. The double bass usually sounds one _____ lower than written.
9. The double bass usually uses the _____ clef although it can sometimes use the tenor clef and even occasionally the treble clef.
10. The double bass is the _____ sounding member of the string section.

Octave
Lowest
4

Largest
Jazz
Violone

Bass
French
Stand

Simandl
Sixteenth

Name: _____

THE HARP - Factsheet

The harp has the largest range of any orchestral instrument. It became a regular feature of the orchestra in the Romantic period (the nineteenth century). Simple harps however existed for many centuries before.

The harp is a very versatile instrument indeed. A harpist can pluck single strings or play several strings at one time producing chords. Some of the strings are differently coloured to guide the player. On a modern harp there are 47 strings.

Harp has a double action mechanism, this enables the player to alter the pitch of the instrument by up to a tone by using one of three pedals. Some harps have up to seven pedals so that the pitch of all strings with the same letter name can be altered.

Harp music is written on two staves rather like piano music and it uses both treble and bass clef.

When a harpist plays a fast, rippling scale it is called a glissando and it is perhaps this sound that most people associate with the instrument.

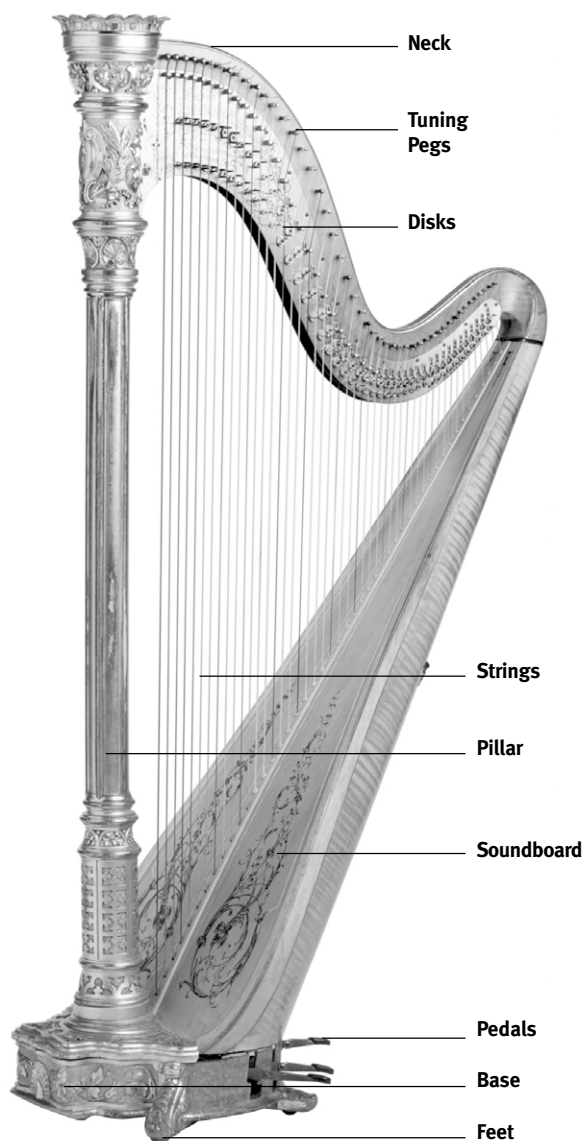

Famous works for harp:

Carmen	Bizet
Introduction et allegro	Ravel
Sonata for harp	Hindemith
Concerto for flute, harp and orchestra	Mozart

The harp may be known as the instrument of the angels but with all its strings and pedals it can be a devil to play!

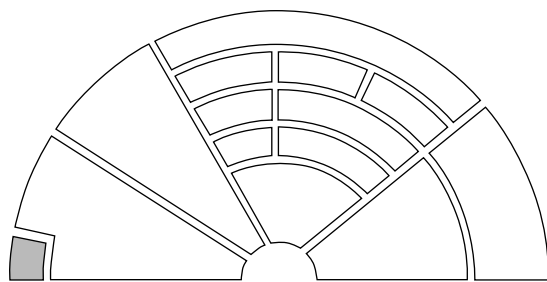

Orchestral position

Harp pitch range

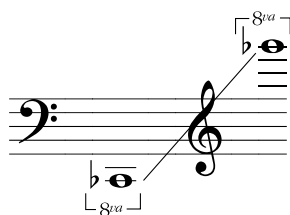

Famous harpists

Marcel Grandjany
Alfonse Hasselmans
Henriette Renie
Carlos Salzedo

Name: _____

THE HARP - Worksheet

Read the statements below and answer true or false, then label the diagram of the harp.

1. The pedals on a harp are used to change the pitch of the instrument? _____
2. When a harpist plays a rippling scale it is called a glissando? _____
3. The strings on a harp are usually just one colour? _____
4. The harp can have as many as seven pedals? _____
5. The harpist usually leads the string section of an orchestra? _____
6. Mozart wrote a concerto for flute, harp and orchestra? _____
7. The harpist usually plays using a bow? _____
8. The harp became a regular member of the orchestra in the 19th century? _____
9. There are 57 strings on a modern harp? _____
10. Harp music is written on two staves? _____

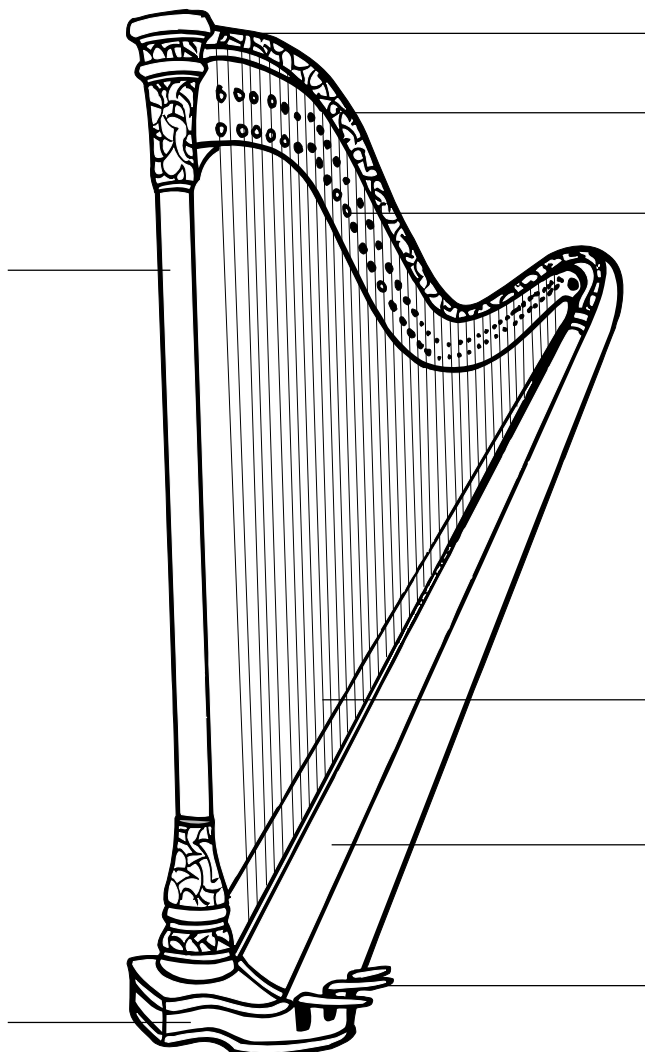

Name: _____

THE STRING SECTION - Factsheet

The orchestra has steadily grown in size throughout the centuries and the string section forms the largest part of an orchestra. In a Baroque orchestra there would have been around six violins, three violas, two cellos and one double bass. By the Romantic period the violins had been divided into two groups; 1st violins and 2nd violins and like today there were generally at least thirty violins, twelve violas, ten cellos and eight double basses.

Another stringed instrument that can be found in the orchestra is the harp. Only one or two of these instruments, if any, are used as many composers do not include this instrument when writing music.

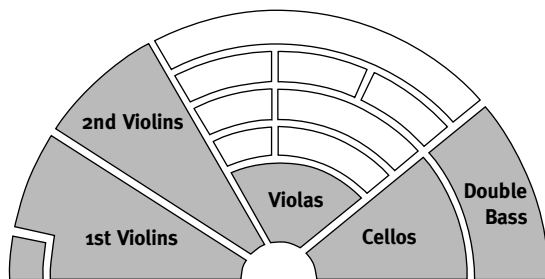

Orchestral positions of the string section

Violin pitch range

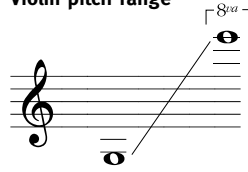

Harp pitch range

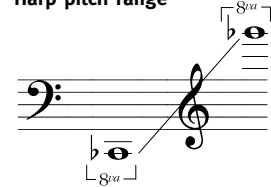

Viola pitch range

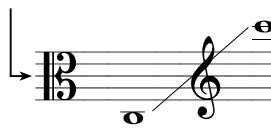

Cello pitch range



Double bass pitch range
(sounds one octave lower than written)

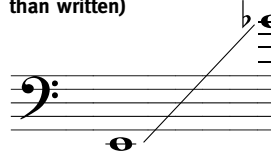

Harp



Violin



Viola



Cello



Double Bass

Name: _____

THE STRING SECTION - Worksheet

Here is a diagram of the layout of an orchestra. Shade in where the string section would sit and write the instrument names in the appropriate boxes.

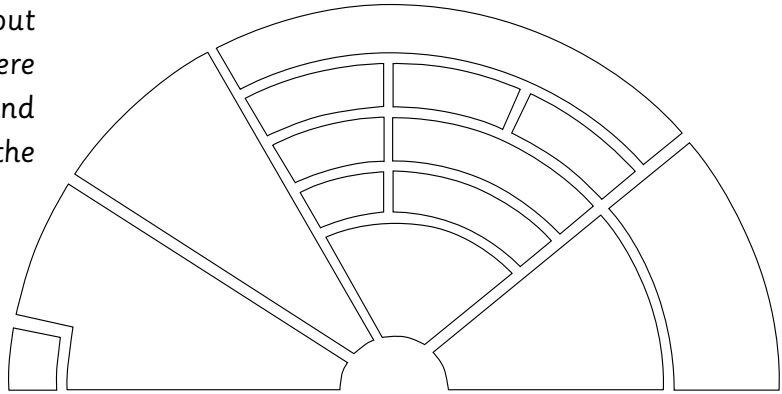

Here is a picture of a cello and its bow, try to label the various parts.

- | | |
|-------------|-------------|
| Tuning Pegs | Fingerboard |
| Bridge | Soundboard |
| Strings | Nut |
| Tailpiece | Hair |
| Scroll | Point |
| Peg Box | Stick |
| Spike | Sound Hole |

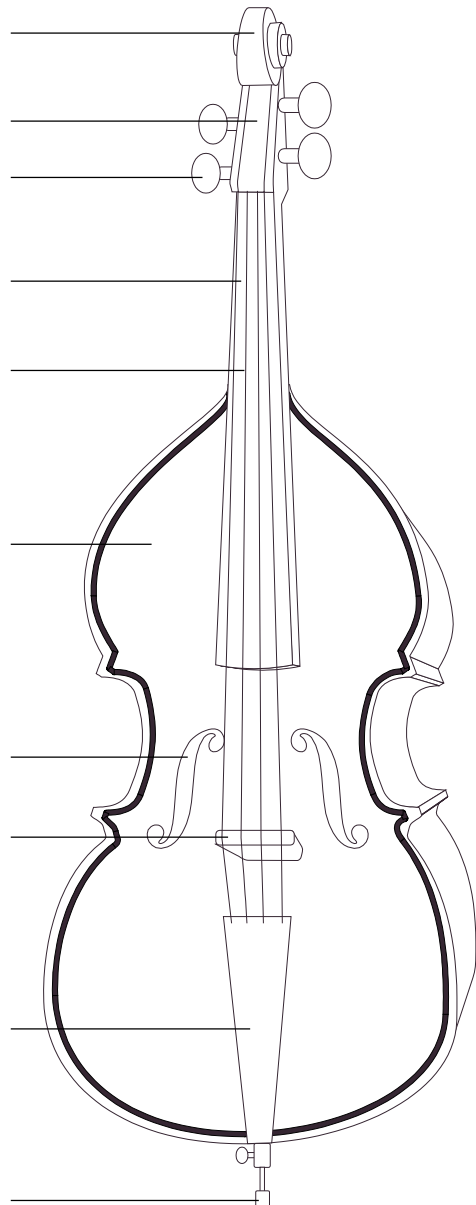
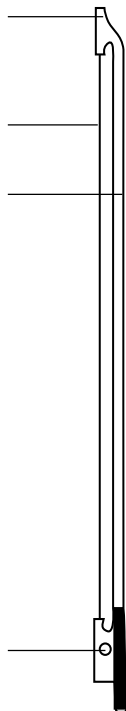

Instruments of the Orchestra

Photocopiable Factsheets & Worksheets
on the Woodwind Section

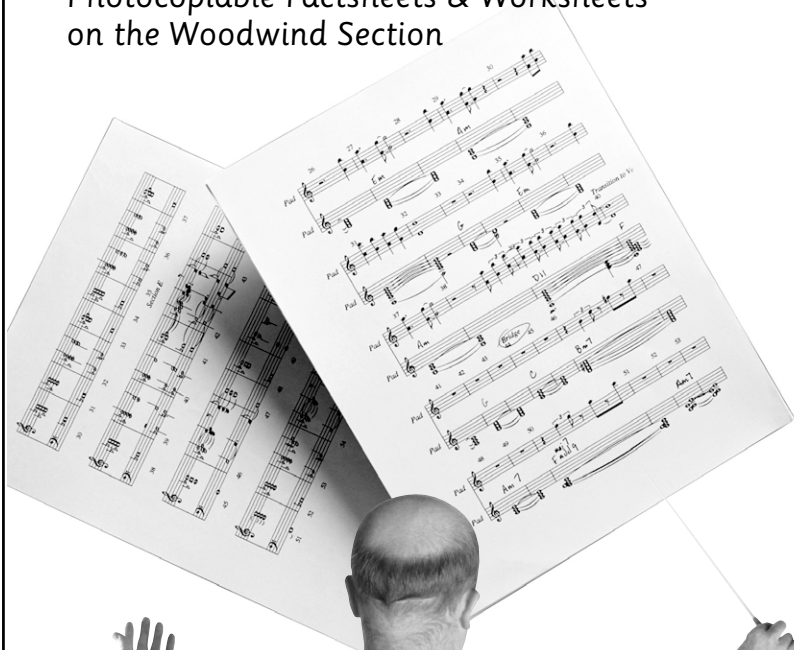

THE FLUTE & PICCOLO - Factsheet

The flute as we know it first came to Europe in the twelfth century and was originally used in military bands. By the seventeenth century the flute was used mostly in orchestras and its design gradually began to change.

The Hotteterre family from France were the first to really alter the design of the flute. The design of the Hotteterre flute had three sections and one key rather than just holes. Theobald Boehm added more keys and his flutes which were developed in the nineteenth century, have become the basis for modern flute design. This is called the Boehm System.

Both the flute and the piccolo are transverse or side blown instruments in which the player blows across the hole in the mouthpiece. The piccolo sounds one octave higher than the flute and its music is written one octave lower than it sounds. The word piccolo means 'little' in Italian and you can see from the picture that it is smaller than the flute. Flutes and piccolos can be made of either wood, silver, nickel or gold plated. The instruments commonly found in the orchestra are usually made of metal rather than wood. The fingering for both the flute and piccolo is identical.

The alto flute or flute in G is larger than the standard flute and is not used very often in the orchestra. The alto flute is what is called a transposing instrument. This means that the notes sound a fourth higher than written. If for example, you see the written note C, the note actually played and heard is an F which is four notes higher. There are also many different types of wooden flutes used in world music.

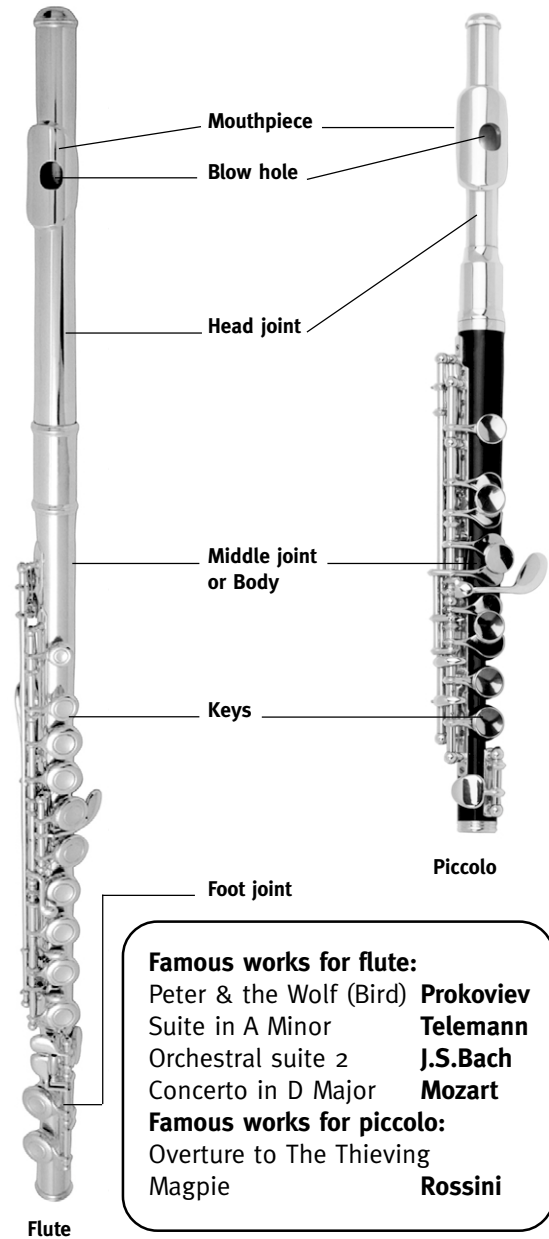

Famous works for flute:

Peter & the Wolf (Bird)	Prokofiev
Suite in A Minor	Telemann
Orchestral suite 2	J.S.Bach
Concerto in D Major	Mozart

Famous works for piccolo:

Overture to The Thieving	Rossini
Magpie	

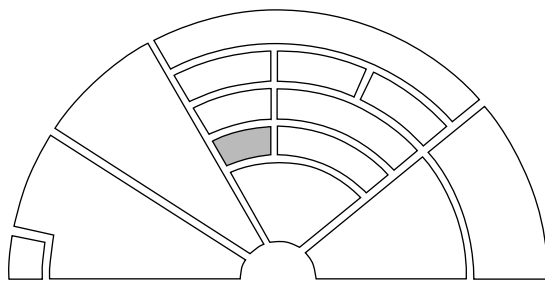

Orchestral position

Flute & Piccolo pitch range

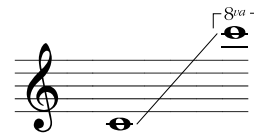

The flute sounds as written and the piccolo sounds one octave higher.

Famous flautists

James Galway
Jeanne Baxtresser
Sebastian Bell
Johann Quantz
Jean-Pierre Rampal

Name: _____

THE FLUTE & PICCOLO - Worksheet

Label the diagrams of the flute and piccolo.
Remember that most of the names are shared
between the two instruments.

Below are 8 questions and answers. Match the
answer to the question.

1. What is another name for the modern flute?

2. What is the literal meaning of the word piccolo
in Italian? _____
3. How much higher does the piccolo sound than
the flute? _____
4. What was the name of the French instrument
makers who first developed the design of the
flute? _____
5. What is the name of the key system used on
most flutes today _____
6. When was the flute first introduced into
Europe? _____
7. The flute was first used in what kind of band?

8. The other name for the flute in G is?

Little
Transverse Flute
Alto Flute
One Octave

Twelfth Century
Military Bands
Boehm System
Hotteterre

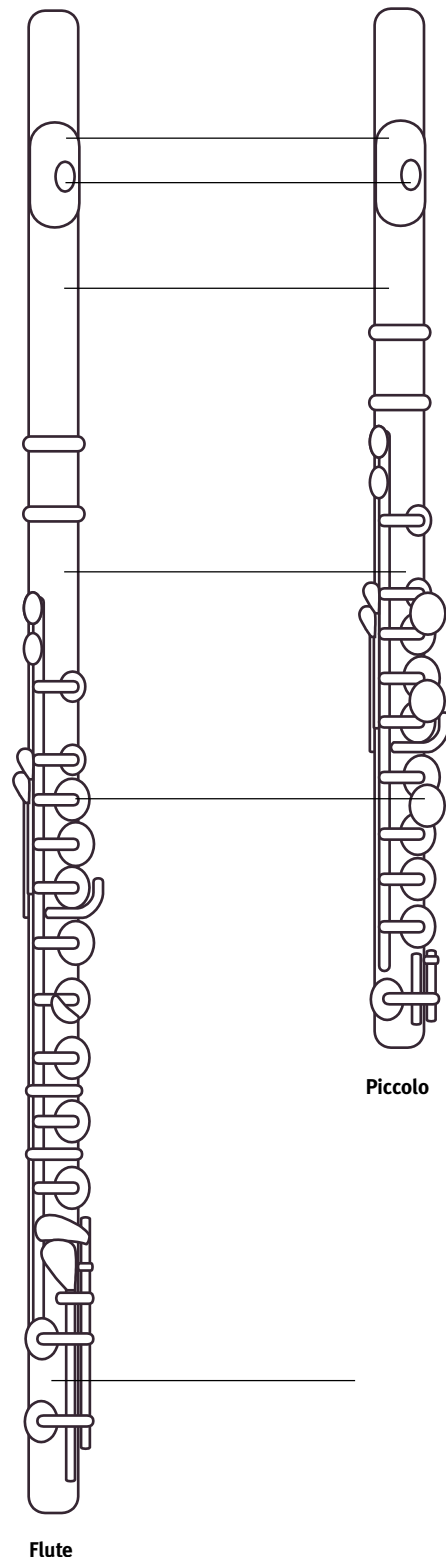

Name: _____

THE CLARINET - Factsheet

The clarinet developed from the older instrument called the chalumeau in the early 1700's by a German instrument maker called J.C.Denner. The clarinet had a separate mouthpiece and extra keys which meant that it could play a wider range of notes. In the 1840's the Boehm system of keys which had been developed for the flute were also added to the clarinet.

The clarinet is a single reed instrument with a piece of cane or plastic shaped to fit to the main part of the mouthpiece. The clarinet generally found in the orchestra is a B flat or A clarinet.

Clarinets are what are called transposing instruments. In music for a B flat clarinet a written note C actually plays a B flat on the instrument - one whole tone lower. In a clarinet in A if you see the note C the clarinet will sound an A which is two tones or a minor third lower.

The clarinet is often used in jazz bands and one of the most famous performers on the clarinet was Acker Bilk. The clarinet has seen a rise in popularity in recent years and has become much easier for young people to learn with the development of the C clarinet. This instrument is made of a lightweight plastic and enables players to start at an earlier age, as it is smaller and lighter.

The basset horn in F is a lower sounding clarinet that is rarely found today but it was popular during the Classical period. There are also clarinets in E flat and a bass clarinet in B flat.

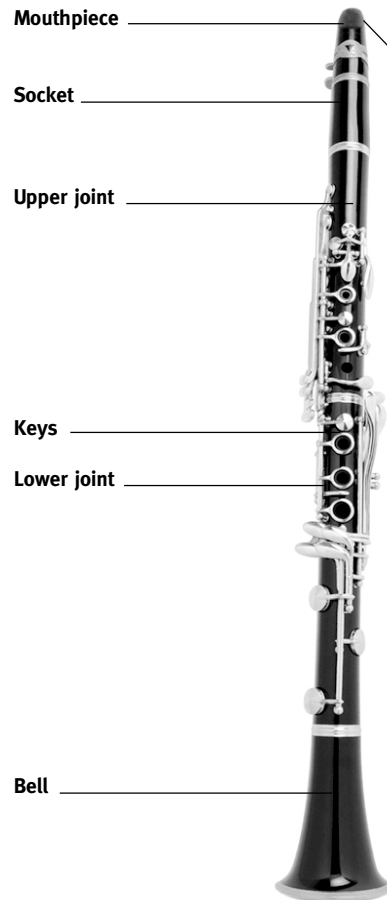

A clarinet single reed - this fits onto the mouthpiece on the underside.

Famous works for clarinet:

Rhapsody in Blue	Gershwin
Concerto in A Major	Mozart
Peter & the Wolf (Cat)	Prokofiev
Quintet for clarinet & strings	Brahms
The Miraculous Mandarin	Bartok

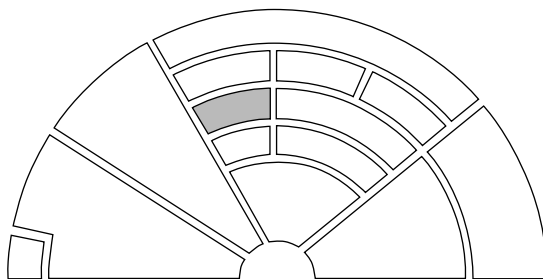

Orchestral position

B flat Clarinet pitch range

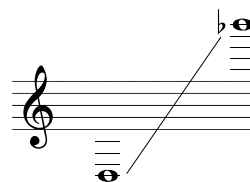

Famous clarinetists

Acker Bilk
Jack Brymer
Gervase de Payer
Emma Johnson

THE CLARINET - Worksheet

Label the diagram of the clarinet and then find these words associated with the clarinet in the wordsearch below.

Reed

Denner

Contrabass

Acker Bilk

Basset Horn

Chalumeau

Boehm

Transposing

Jazz

Woodwind

T	B	S	U	T	K	X	D	F	B	C
A	R	E	E	D	C	M	E	Y	A	O
C	T	A	S	U	E	V	N	A	S	N
H	R	R	N	A	W	L	N	C	S	T
A	O	D	Q	S	Z	V	E	K	E	R
L	P	Q	V	E	P	B	R	E	T	A
U	F	J	P	N	Z	O	G	R	H	B
M	P	A	O	G	M	E	S	B	O	A
E	H	Z	B	I	A	H	L	I	R	S
A	K	Z	N	H	J	M	K	L	N	S
U	D	G	E	C	M	S	F	K	J	G
W	O	O	D	W	I	N	D	L	I	K

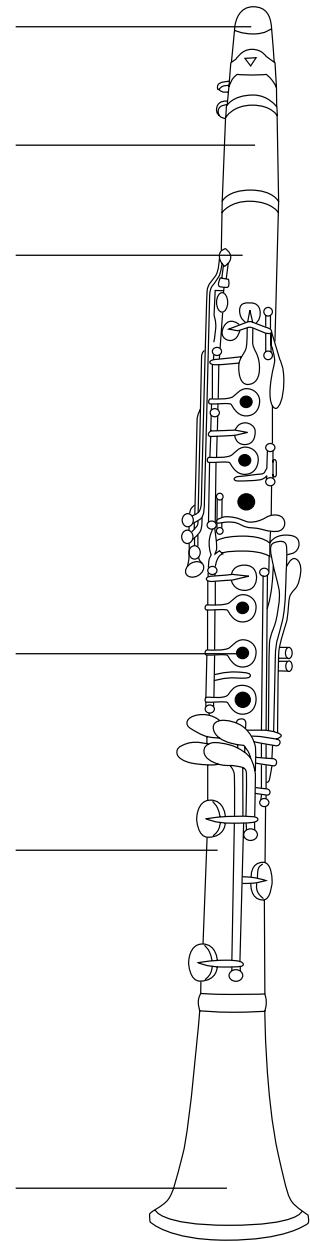

Answer true or false to the following statements about the clarinet.

1. The clarinet developed from the earlier instrument the chalumeau? _____
2. The basset horn was most often found in the orchestra during the Romantic period? _____
3. The B flat clarinet is becoming a popular instrument for young musicians to start learning on? _____
4. The clarinet is a single reed instrument? _____
5. The B flat and A clarinet are transposing instruments? _____

THE OBOE - Factsheet

The oboe was originally developed from the early reed instrument the shawm. It was the Hotteterre family who worked for the court of Louis XIV that developed the earliest known oboes. The nineteenth century saw the development of a key mechanism and although these can vary from maker to maker they are fairly standardised today.

The oboe is made in three sections and there are several different sizes used in the orchestra including the cor anglais which is slightly larger than the oboe.

The oboe is a double reed instrument unlike the clarinet, which is a single reed instrument. To make an oboe reed a length of cane is split into three and the pieces are shaped, bent and tied tightly to form a mouthpiece.

They vibrate when a player blows air through the reed and sound is produced. In France the oboe is called the hautbois which literally means high wood and you will sometimes see this written in musical scores.

The oboe d'amore which literally means the oboe of love was developed around 1720 in Germany and is larger than the oboe. It was popular during the Baroque period and Bach used it extensively.

The oboe sounds as it is written, whereas the cor anglais sounds a fifth lower and the oboe d'amore a third lower than it is written.

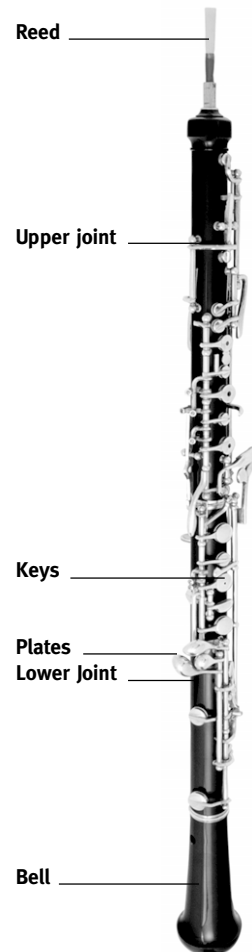

Famous works for oboe:

Peter & the Wolf (Duck)
Concertos
The Silken Ladder Overture

Prokofiev
Albinoni
Rossini

Famous works for cor anglais:

New World Symphony

Dvorak

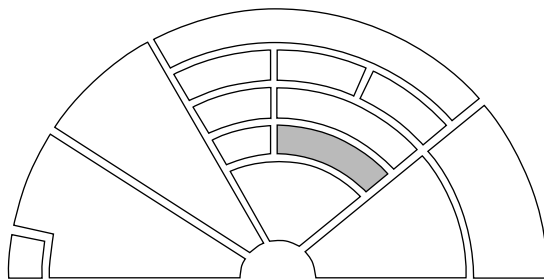

Orchestral position

Oboe pitch range

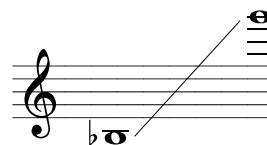

Famous oboe players

Georges Gillet
Robert Bloom
Lady Evelyn Barbirolli
Myrtille Morel

THE OBOE - Worksheet

Label the diagram then answer the following questions.

1. What instrument was the oboe developed from?

2. Which instrument maker produced the first oboes for the French court? _____
3. Which clef does both the oboe and cor anglais use? _____
4. What kind of reed does an oboe use?

5. What was the main development in oboe design during the nineteenth century?

6. Which instrument related to the oboe sounds fifth lower than it is written?

7. The oboe d'amore was most popular in which period? _____
8. How many sections does an oboe have?

9. The oboe is used to depict what animal in Peter and the Wolf? _____
10. The French name for the oboe is?

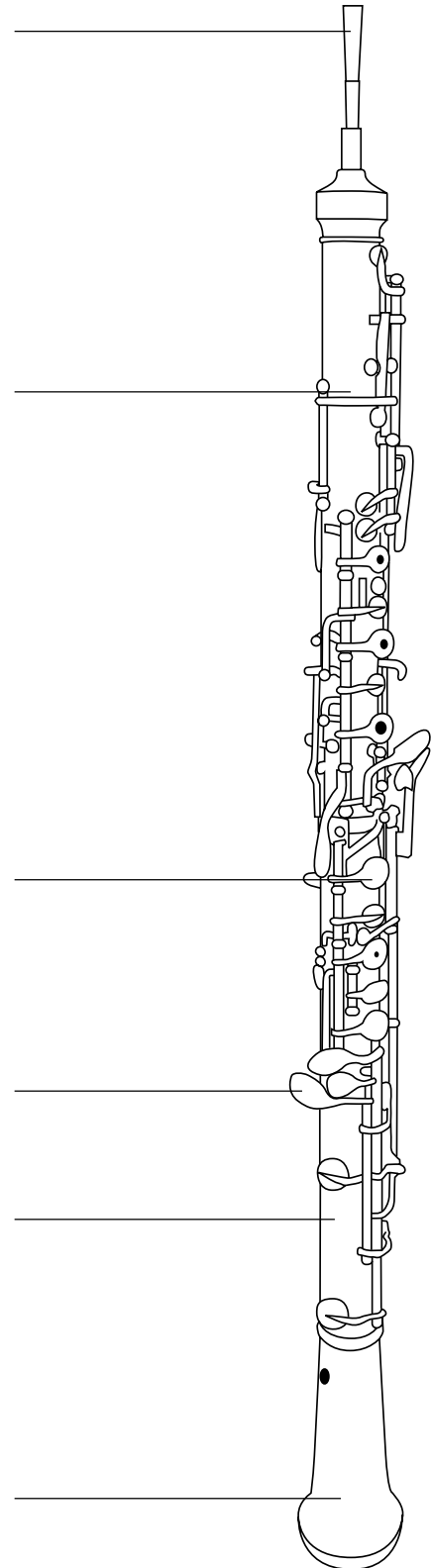

The answers to the questions above can be found mixed up below.

Cor anglais	Hautbois	Three
Baroque	Double reed	Keys
Shawm	Hotteterre	Duck
Treble		

THE BASSOON - Worksheet

Label the diagram of the bassoon then answer true or false to the following statements.

1. The bassoon is a single reed instrument? _____
2. The bassoon has four sections or joints? _____
3. The reed in a bassoon fits into the crook? _____
4. The bassoon was developed from the shawm in the 17th century? _____
5. Music for the bassoon is usually written in the bass clef? _____
6. The contrabassoon is higher in pitch than the bassoon? _____
7. The bassoon is used in the Sorcerer's Apprentice by Paul Dukas to play the main theme? _____
8. The German instrument maker who devised a system of keys for the bassoon is Wilhelm Heckel? _____
9. The bassoon was not found in the orchestra until the Romantic period? _____
10. The company Crampon-Buffet made the French bassoon? _____
11. The bassoon is the largest member of the woodwind section commonly found in the orchestra? _____
12. The bassoon originally only had two keys? _____
13. The crook is attached to the butt joint? _____
14. The bassoon is used in the Rite of Spring by Shostakovich? _____
15. Archie London is a famous bassoonist? _____

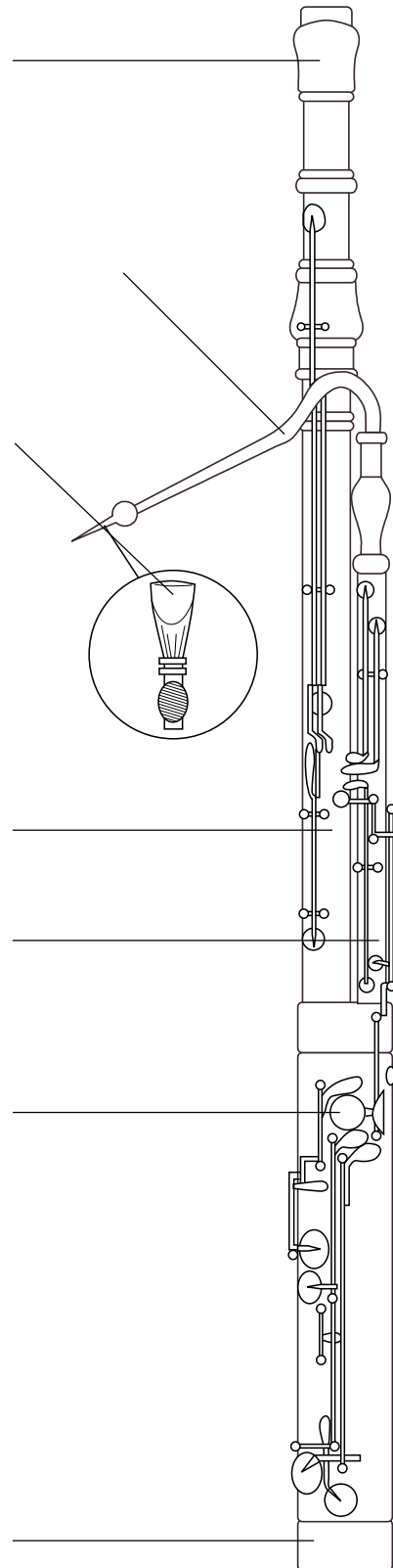

THE WOODWIND SECTION - Factsheet

The instruments in the woodwind section can vary greatly and it depends in what period the music being performed was written as to which instruments are found. In a Baroque orchestra you would generally have found two oboes, one oboe d'amore, one oboe de caccia and one bassoon.

The oboe d'amore is slightly lower in pitch than the oboe and the oboe de caccia which literally means hunting oboe was a predecessor to the cor anglais. It has a lower pitch than the oboe.

In a Classical orchestra the woodwind section would have comprised of two flutes, two oboes, two clarinets and two bassoons.

The Romantic orchestra which was much larger in size included one piccolo, three flutes, three oboes, one cor anglais, three clarinets, one bass clarinet, three bassoons and one contrabassoon. These numbers are approximate as different pieces of music would have required different instruments. Modern orchestras have very similar woodwind sections to Romantic orchestras but in some more modern music you will occasionally find the saxophone added to the wind section.

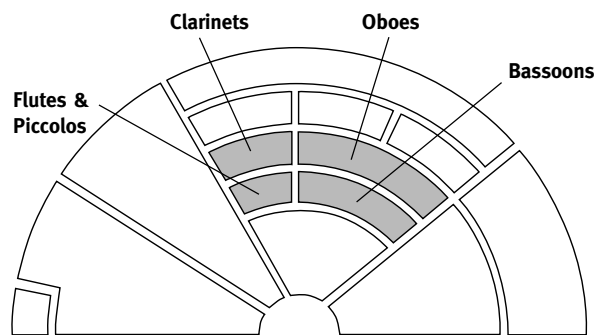

Orchestral position of the woodwind section



Bassoon

Double Reed for Oboes & Bassoons

Single Reed for Clarinets

Oboe

Clarinet

Flute

Piccolo

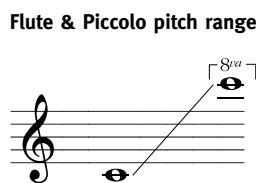
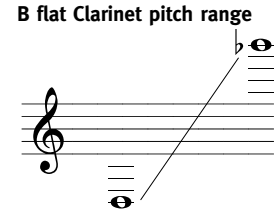
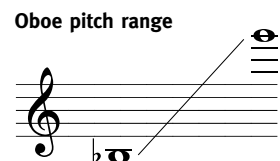

The flute sounds as written and the piccolo sounds one octave higher.

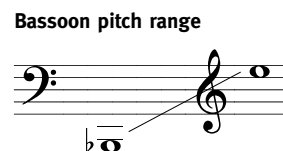

Name: _____

THE WOODWIND SECTION - Worksheet

Here is a diagram of the layout of an orchestra. Shade in where the woodwind section would sit and write the instrument names in the appropriate boxes.

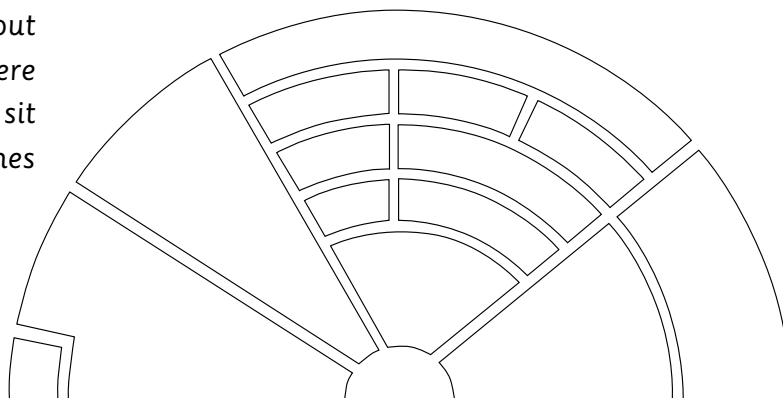

Here is a list of some woodwind instruments. Place them in the table below according to what kind of mouthpiece they use.

Flute	Oboe	Clarinet	Piccolo
Bassoon	Cor Anglais	Saxophone	Bass Clarinet
Oboe d'amore	Contrabassoon	C Clarinet	Recorder

Mouthpiece	Single Reed	Double Reed

Answer the following questions on the woodwind section. Use a notebook or the back of the paper to write on.

1. Which is the highest member of the woodwind section found in the orchestra?
2. Which is the lowest instrument of the woodwind family commonly found in the orchestra today?
3. Which instruments would you find in a Romantic period orchestra in the woodwind section that you would not find in a Baroque period orchestra?
4. Is the oboe d'amore higher or lower in pitch than the orchestral oboe?
5. Which instrument more often used in jazz is sometimes found in the modern orchestra?

Instruments of the Orchestra

Photocopiable Factsheets & Worksheets
on the Brass Section

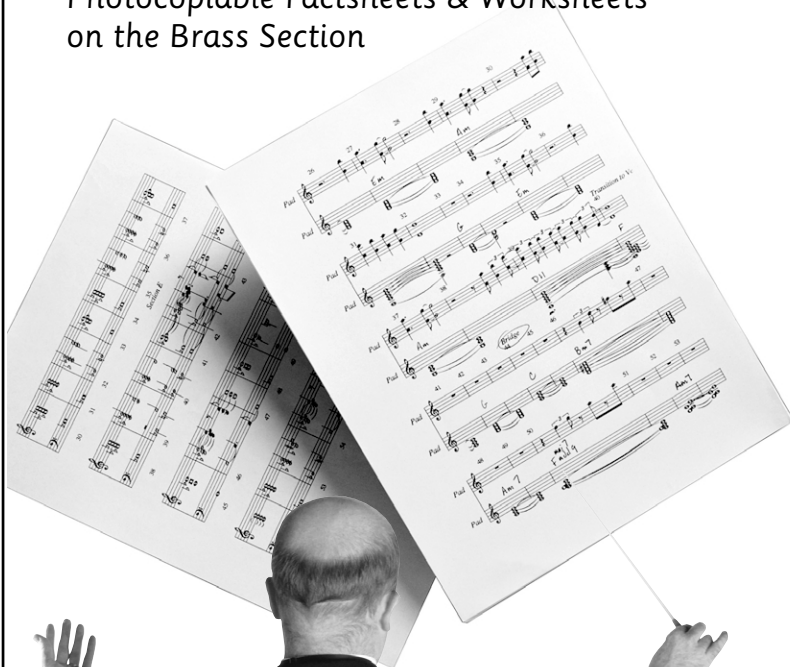

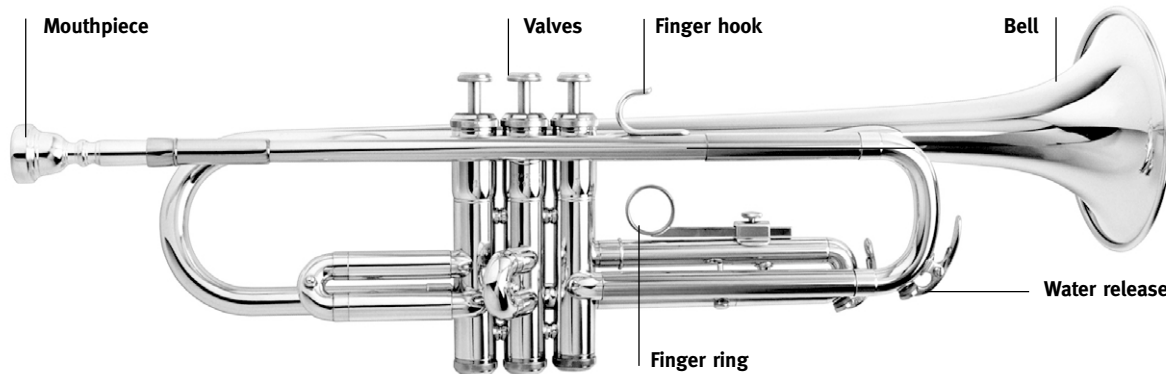
THE TRUMPET - Factsheet

The modern trumpet developed from the natural trumpet which was an instrument with a very limited range as it had no valves or keys and could only play high notes.

The natural trumpet was extremely difficult to play and in the eighteenth century instrument makers began to try to find a solution to this problem. It wasn't until the nineteenth century however that Stölzel and Blühmel produced the first valve trumpet. The addition of valves made the trumpet both easier to play and increased its range.

Famous works for trumpet:

Trumpet Concerto	Haydn
Trumpet Voluntary	Clarke
Brandenburg Concerto No.2	Bach
The Messiah (The trumpet shall sound)	Handel

If you blow down a trumpet without a valve pressed down then the air can pass straight through the instrument. By pressing down one or more valves the air passes through extra sections of tubing and different notes can be played. Most trumpets have three valves.

Like the clarinet the trumpet is a transposing instrument and the modern B flat trumpet, which is most commonly found in the orchestra, sounds one tone lower than written. Using a mute, a cup or a wow-wow can vary the sound of a trumpet! These all fit into the flared bell and alter the tone of the instrument.

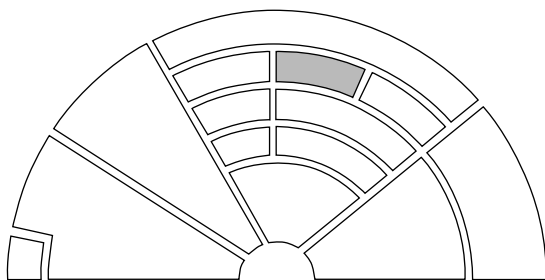
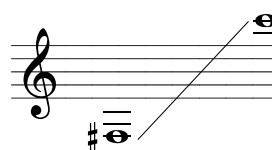
**Natural Trumpet****Orchestral position****Trumpet in B flat pitch range Famous trumpeters**

Miles Davis
Hakan Hardenberger
Wynton Marsalis
Clifford Brown
Louis Armstrong

THE TRUMPET - Worksheet

Label the diagram and then answer the questions about the trumpet below.

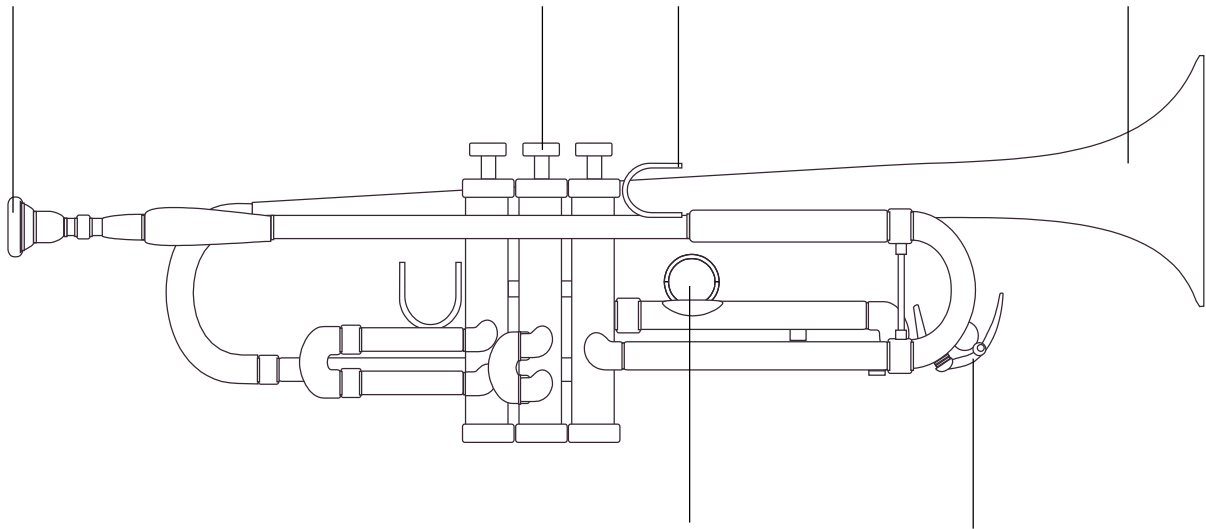

1. How many valves does a modern trumpet have? _____
2. What is a natural trumpet? _____

3. What was the name of the company that developed the valved trumpet in the 19th century? _____

4. What clef does the trumpet usually play in? _____
5. Name two famous trumpeters? _____
6. The trumpet is a transposing instrument. What does this mean? _____

7. What is the flared end of a trumpet called? _____
8. Which type of trumpet is commonly found in orchestras today? _____
9. What can be placed into the end of a trumpet to alter the sound? _____
10. Why did the addition of valves to the trumpet have such an impact on the development of the instrument? _____

THE TROMBONE - Factsheet

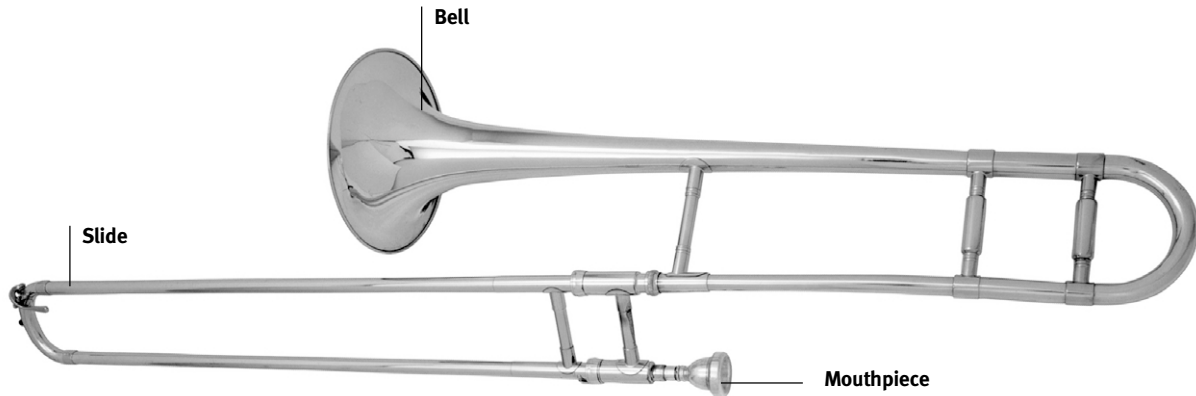

The trombone generally found in orchestras today is the slide tenor trombone although in the twentieth century a three-valve trombone was successfully developed. There are usually three or four trombones in a symphony orchestra.

As with other brass instruments the vibrations of the performer's lips produce and vary the sound. The slide trombone uses a slide to extend the length of tubing. There are seven playing positions, which combined with the players breath pressure change the pitch of the notes.

Famous works for trombone:

Ride of the Valkyries	Wagner
Symphony No.5	Beethoven
William Tell Overture	Rossini
Requiem (Tuba Mirum)	Mozart
Tannhäuser Overture	Wagner

The trombone is developed from the earlier instrument the sackbutt, which was popular during the 1400's and 1500's. Originally used mostly in church music, it wasn't until the nineteenth century that the trombone became a regular member of the orchestra.

There are several different sizes of trombone the tenor, bass and tenor bass trombones. Unlike many brass instruments the tenor trombone which is the most popular in orchestral music is not a transposing instrument, so its music sounds as written. A strange fact is that if the same instrument is used in brass bands its music is written a ninth higher than played and written in the treble clef and not the tenor or bass clef. The tenor trombone usually uses the bass clef or tenor clef.

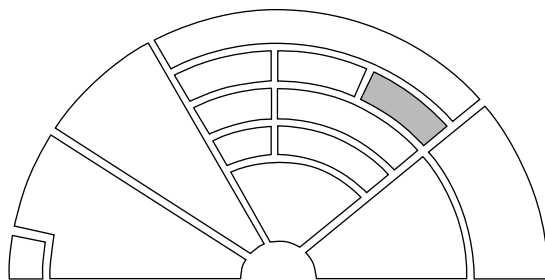

Orchestral position

Trombone pitch range



Famous trombone players

Simon Hogg
Christian Lindberg
Bill Watrous
Don Lusher

THE TROMBONE - Worksheet

Draw in the missing instrument parts and label the diagram and then answer true or false to the 10 statements about the trombone.

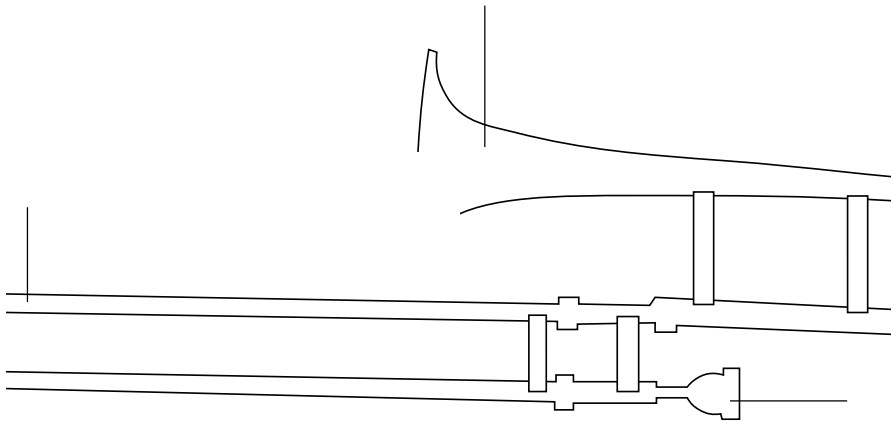

1. The trombone was developed from the earlier instrument the sackbutt? _____
2. There are five playing positions on the trombone? _____
3. The tenor trombone usually uses the alto clef? _____
4. The valve trombone was invented in the twentieth century? _____
5. There are usually six trombones in a modern symphony orchestra? _____
6. Wynton Marsalis is a famous jazz trombonist? _____
7. The tenor trombone when used in the orchestra is a transposing instrument? _____
8. The most popular type of trombone is the soprano trombone? _____
9. Symphony No.9 by Beethoven includes a famous trombone solo? _____
10. Trombones were originally most popular in church music? _____

Below write a short paragraph about the trombone.

THE HORN - Factsheet

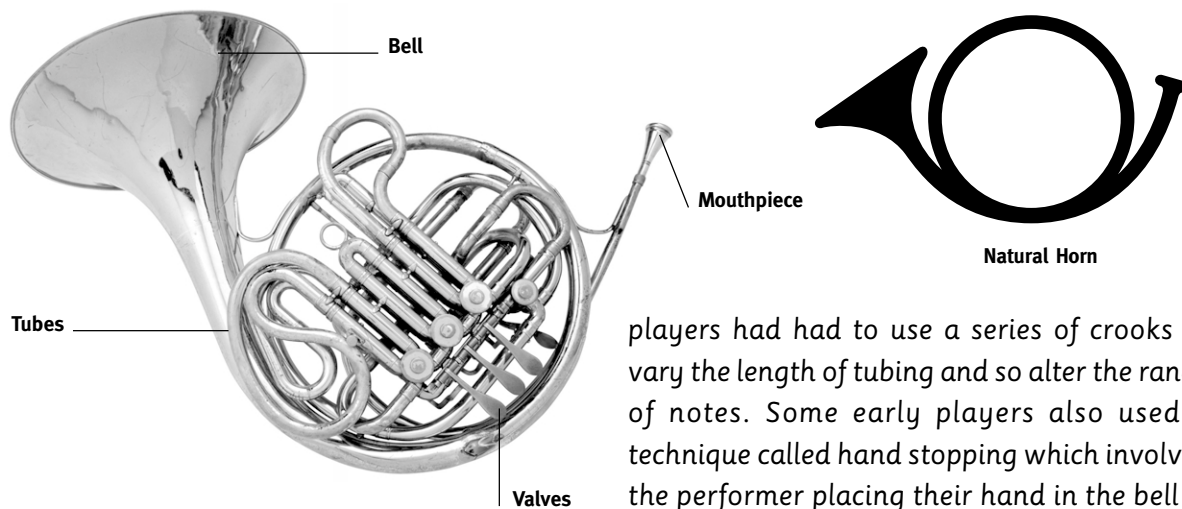

The horn has been found throughout history and was originally used as a signal both when hunting and in battle. The earliest horns were made of animal horn but in the fourteenth century instrument makers began to use metal instead. The orchestral or French horn was developed in the seventeenth century.

It was the addition of valves which revolutionised horn playing as previously

players had had to use a series of crooks to vary the length of tubing and so alter the range of notes. Some early players also used a technique called hand stopping which involved the performer placing their hand in the bell of the instrument to alter the pitch of the notes.

There are two types of horn commonly found today, the horn in F and the double horn in B flat. The double horn in B flat can alternate between F and B flat by use of a valve, therefore living up to its name of double horn by being able to be played as either a B flat or F horn. The double horn is most commonly found in orchestras as it is more versatile.

When playing a horn the performer supports the instrument by placing their hand into the bell. By changing the hand position the player can alter the pitch, mute the sound or produce various other effects. A pear shaped mute can also be inserted into the bell to change the sound.

Famous works for horn:

Peter & the Wolf (Hunters)	Prokofiev
4 Horn Concertos	Mozart
Brandenburg Concerto No.1	J.S.Bach
Concerto in D Major	Haydn
Concerto for 4 Horns	Schumann

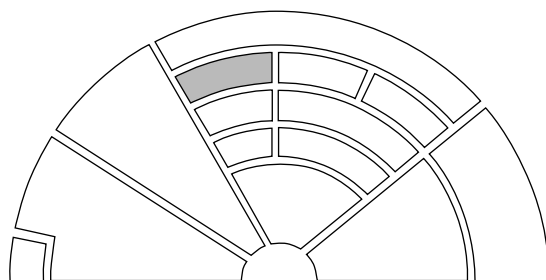

Orchestral position

Horn in F pitch range
(written)

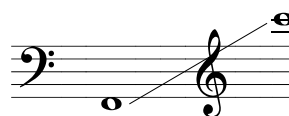

Famous horn players

Dennis Brain
Michael Thompson
Hermann Baumann
Anthony Halstead

THE HORN - Worksheet

Label the diagram of the horn.

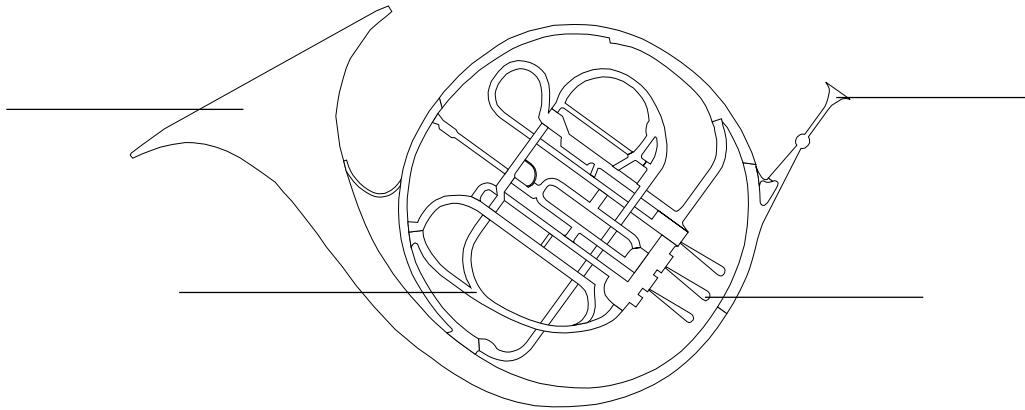

Answer true or false to the following statements about the horn.

1. The triple horn is the most commonly found in the orchestra? _____
2. The horn was originally used as a signal in hunting? _____
3. The orchestral horn was developed in the seventeenth century? _____
4. The double horn in B flat can alternate between F and B flat by use of a valve? _____
5. You can alter the pitch of the instrument by moving your hand in the bell? _____

F	A	H	B	E	M	L	A	D	O	P
R	E	V	C	N	U	O	D	O	D	R
E	A	L	A	V	T	S	A	U	N	O
N	T	U	E	L	E	X	C	B	E	K
C	R	O	O	K	V	D	L	L	U	O
H	C	F	C	B	T	E	A	E	N	V
H	U	N	T	I	N	G	V	H	I	I
O	O	N	G	O	S	R	B	O	M	E
R	C	B	R	A	S	S	E	R	I	V
N	L	N	O	Y	X	E	L	N	D	Z
W	M	O	Z	A	R	T	L	K	H	F

Find the words connected with the horn in the wordsearch.

Bell
Hunting
Crook
Valve
Double Horn
French Horn
Brass
Prokofiev
Mozart
Mute

Name: _____

THE TUBA - Factsheet

The tuba is the largest member of the brass family commonly found in the orchestra. For a large instrument it is surprisingly versatile.

It was invented in the 1830's in Germany although it was rarely found in orchestras before 1850. The inventor was a bandmaster named Wieprecht who patented his design with an instrument maker called Moritz. There have been various sizes and shapes of tuba and there are three types used in orchestras today: the contrabass, E flat bass or bombardon and the F bass tuba.

The orchestral tuba usually plays in the bass clef. The word tuba actually comes from the Latin for trumpet which is a little confusing!

Wagner invented a tuba called the Wagner tuba to be used in his series of operas called The Ring Cycle. It is however more closely related to the horn than the tuba.

The marching tuba is used in military bands and rests on the player's shoulder with a lighter fibreglass bell pointing forwards.

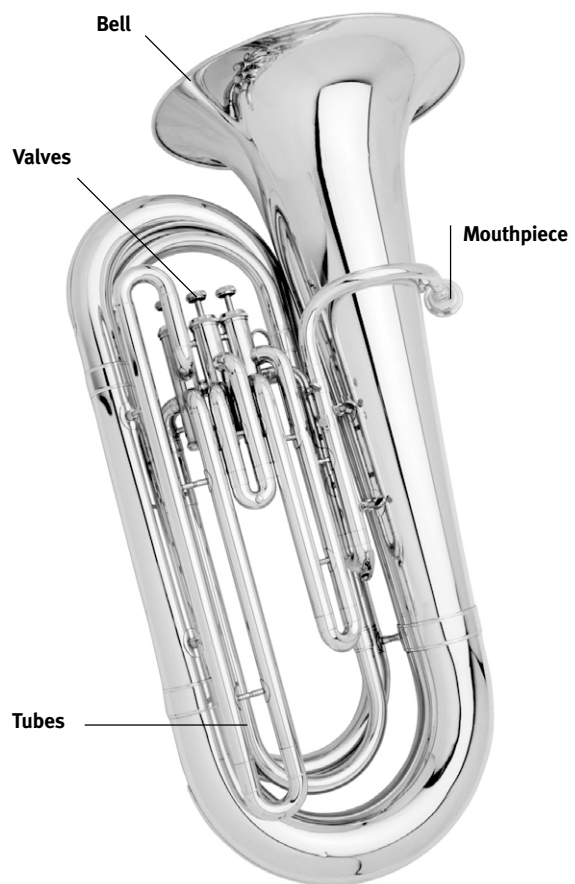

Famous works for tuba:

Concerto for Tuba	Vaughan Williams
Symphonie Fantastique	Berlioz
Tragic Overture	Brahms
Pictures from an Exhibition	Mussorgsky/Ravel

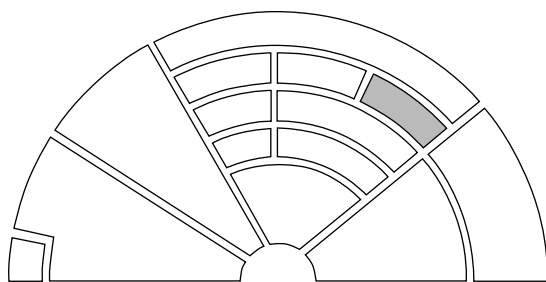

Orchestral position

Tuba pitch range

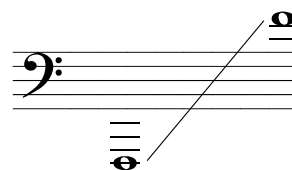

Famous tuba players

John Fletcher
Arnold Jacobs
John Griffiths
Mark Nelson

THE TUBA - Worksheet

Here are 8 questions and answers about the tuba. Draw a line to match the correct question with its answer.

- | | |
|---|----------------------|
| 1. The name of the men who patented the tuba in the 1830's? | Wagner |
| 2. How many valves does a tuba have? | Fibreglass |
| 3. What does the word tuba literally mean? | Moritz and Wieprecht |
| 4. Which composer invented a tuba to be used in his music? | Trumpet |
| 5. The bell of tubas used in military bands are made of this? | Three |
| 6. What is the other name for the E Flat bass tuba? | Germany |
| 7. What clef does the orchestral tuba usually play in? | Bombardon |
| 8. In which country was the tuba invented? | Bass |

Fill in the missing parts of this drawing of the tuba and then label the instrument.

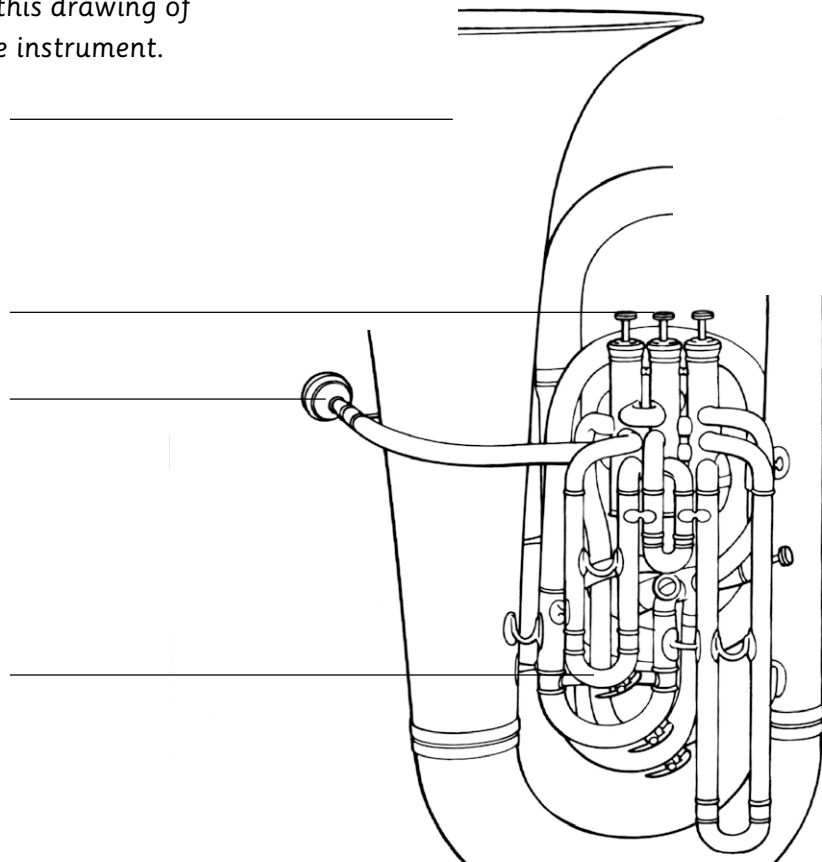

THE BRASS SECTION - Factsheet

Between 1600 and 1750 the brass section in a Baroque orchestra was quite limited often consisting of only trumpets and horns. It wasn't until around 1850 during the Romantic period that improvements in design made the instruments more reliable. This as well as new instruments being invented led to the brass section increasing in size dramatically.

In the Romantic period the brass section quite often included four horns, four trumpets, four trombones and one tuba.

Wagner sometimes used what is known as the Wagner Tuba in his music. It is more like an orchestral horn than a tuba and is made in two sizes - tenor and bass. It was developed to Wagner's specification and is still used in *The Ring Cycle* of operas along with a bass tuba.

Trumpet



Trombone



Horn



Tuba

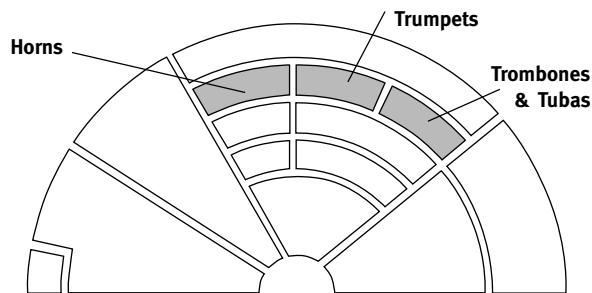

Orchestral positions of the brass section

Trumpet pitch range

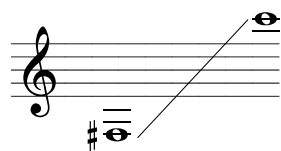

Horn in F pitch range (written)

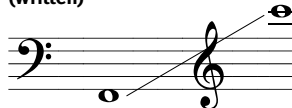

Trombone pitch range



Tuba pitch range

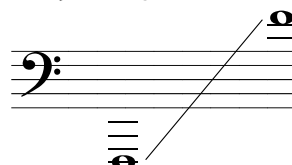

THE BRASS SECTION - Worksheet

Here is a diagram of the layout of an orchestra. Shade in where the brass section would sit and write the instrument names in the appropriate boxes.

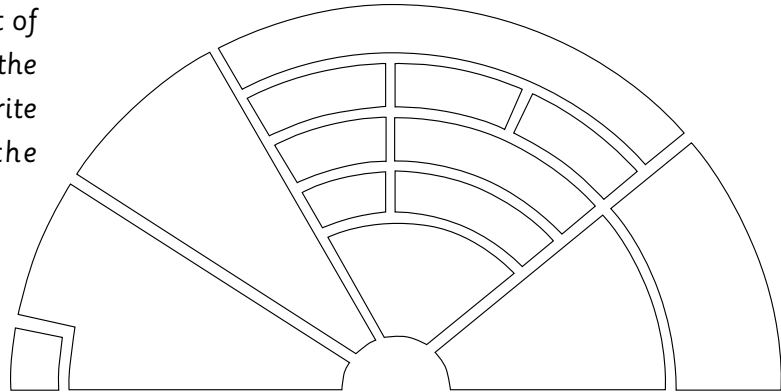

Answer the questions below on the brass section of the orchestra.

1. Which brass instrument uses a slide? _____
2. How many valves does a trumpet have? _____
3. Which brass instrument is the lowest commonly found in the orchestra? _____
4. Which instrument that looks as though it should belong to the brass family is actually a woodwind instrument and is used in jazz music? _____
5. Is the orchestral trumpet a transposing instrument (one that plays a different pitched note to the one that is written on the page)? _____
6. Which brass instrument was developed from the sackbutt? _____
7. How many horns are there in a Romantic period orchestra? _____
8. Which is the highest brass instrument commonly found in the orchestra? _____
9. How many positions are there on the trombone? _____
10. Which composer invented a tuba to be used in his operas? _____

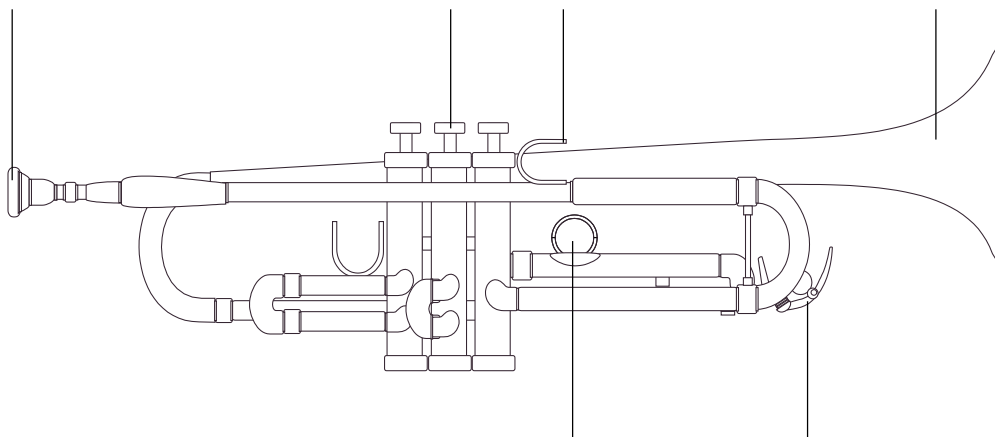

Instruments of the Orchestra

Photocopiable Factsheets & Worksheets
on the Percussion Section

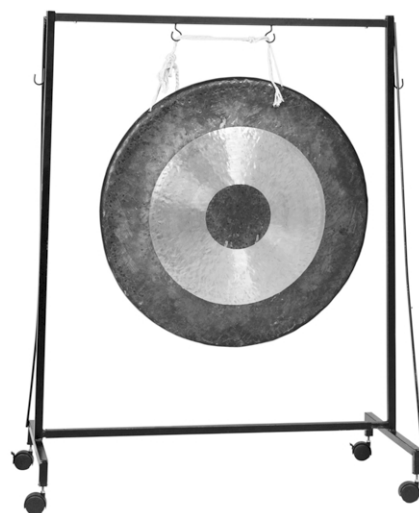
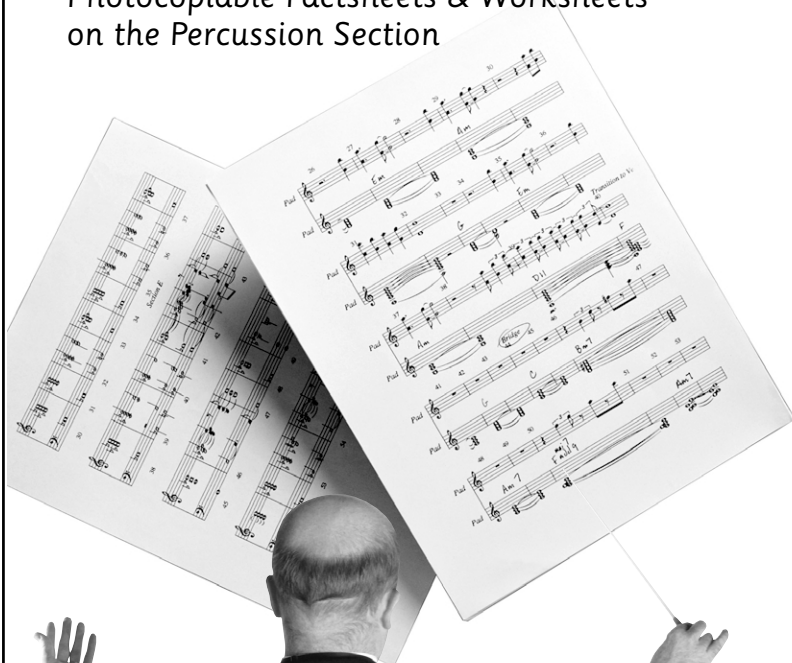

TUNED PERCUSSION - Factsheet

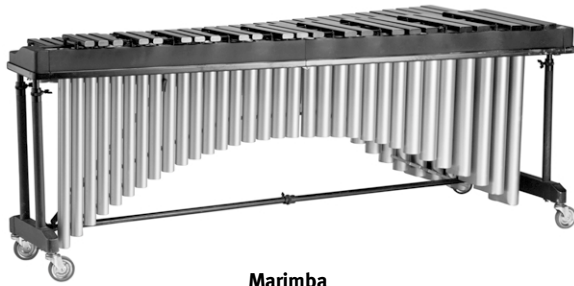

Marimba

The main feature of tuned percussion is that they can play a melody rather than simply make a noise or effect. The most commonly found tuned percussion instruments found in the orchestra are the glockenspiel, xylophone, tubular bells, vibraphone, marimba and the celeste.

The orchestral xylophone has two rows of wooden bars with a range of between 3 1/2 and 4 octaves. The sound is made louder and clearer by resonating tubes which hang underneath the instrument. The wooden bars can be struck with different kinds of beaters to produce a different sound but performers most often use wooden beaters.

Famous works for percussion:

1812 Overture	Tchaikovsky
(Tubular Bells, Vibraphone & Wind Machine)	
Danse Macabre (Xylophone)	Saint-Saens
Sorcerer's Apprentice	Dukas
(Glockenspiel)	

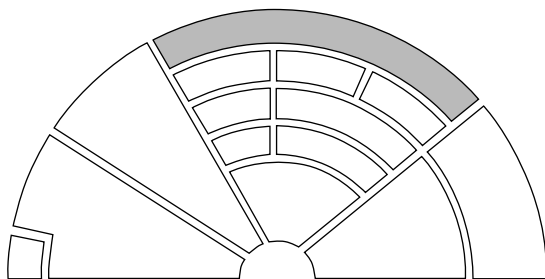

Orchestral position

The marimba is very similar to the xylophone but is deeper in pitch. Its name comes from an instrument found in both Africa and South America.

The glockenspiel has metal bars rather than the wooden bars found on the xylophone and marimba. It also has a smaller range - typically around 2 1/2 octaves. The glockenspiel is usually played with quite hard beaters so that the sound is bright and bell-like. A celeste is a kind of keyboard glockenspiel in which the metal bars are hit by felt covered hammers.

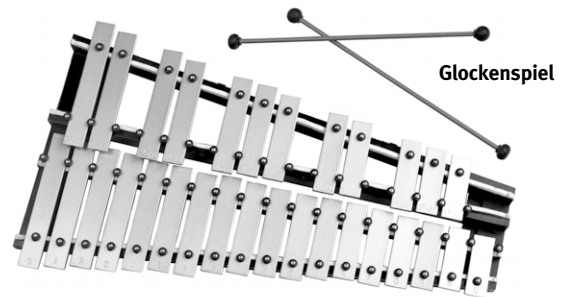

Glockenspiel

The layout of the bars on all these instruments is very similar to the arrangement of the keys on the piano. However as the pitch of the notes becomes higher the metal or wooden bars shorten in length and so the longer the bar the deeper the pitch.

The layout of the tubular bells is different to that of the glockenspiel, xylophone and marimba. A series of 18 brass or steel tubes are hung from a frame ranging from longer, lower pitched tubes to shorter tubes which produce a higher sound. To play the tubular bells the tubes are struck with a hammer. Sometimes the tubular bells have a mechanism that is operated by the foot to stop the sound.

Famous percussionists

Evelyn Glennie
James Blades
Dave Hassel
Jimmy Holland

TUNED PERCUSSION - Worksheet

Answer the following questions about tuned percussion.

1. What is the main feature of tuned percussion instruments? _____

2. What is the range of notes on an orchestral xylophone? _____

3. What is the difference between a xylophone and glockenspiel? _____

4. What is a celeste? _____
5. What is the range of notes on an orchestral glockenspiel? _____

6. What kind of beaters are usually used on a glockenspiel? _____

7. The layout of the bars on the glockenspiel, marimba, xylophone, celeste and vibraphone is very similar to the keys on which instrument? _____
8. What is different about the layout of tubular bells? _____

9. What are the tubes on tubular bells usually hit with? _____

10. What is sometimes used to stop the sound on tubular bells? _____

Unscramble the words below and draw a line across to the instrument that they should spell.

onphexloy

glockenspiel

llebs ubutlra

xylophone

bammira

vibraphone

llokgneciesp

celeste

eteselc

tubular bells

onpherabvi

marimba

UNTUNED PERCUSSION - Factsheet



Sleigh bells



Tambourine



Castanets



Triangle

Untuned percussion instruments cannot play a melody as they do not produce a pitched note or sound. They are usually used to create effects in a piece of music or to play a rhythm. Untuned percussion instruments are usually hit or shaken.

The type of percussion instruments used in an orchestra can vary greatly depending on the period that the piece was written and the effect that the composer is trying to create.

Famous works for percussion:

Facade (Wood Block)	Walton
Carmen (Castanets)	Bizet

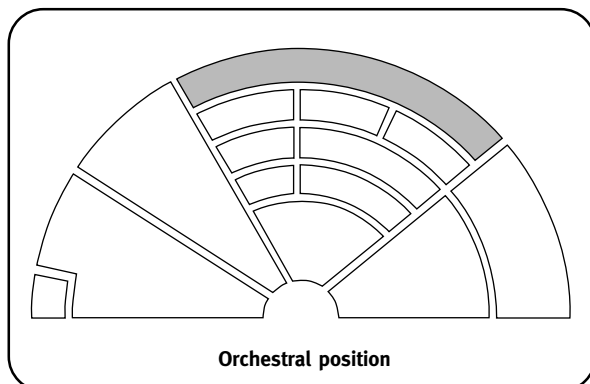

Orchestral position

The cymbals are often used to create grand crashes of lightning or a dramatic flourish in a piece. They can be clashed together or sometimes a single cymbal is hit with a beater.

The triangle has been used for around two hundred years in the orchestra. It is made from a steel bar which is bent into a triangle shape. The triangle is then suspended from one corner so that when hit by a metal beater it produces a bright clear sound.

Tambourines are made using a wooden or metal hoop over which a skin is stretched tightly. By adding metal discs around the outside of the tambourine it makes a jingly sound. The tambourine originated in the Middle East although it has been used in Western music for many centuries.

Castanets originated in Spain and are often used in music with a Spanish flavour. By clicking together the two hollowed-out shaped pieces of wood a strong and surprisingly loud rhythmic effect can be achieved. In the orchestra castanets are often attached to a wooden stick rather than clicked between the fingers.

UNTUNED PERCUSSION - Worksheet

C	O	W	B	E	L	L	A	N	O	B
H	E	M	C	N	C	O	D	S	D	A
I	A	L	R	V	J	S	A	N	N	S
M	T	U	E	S	L	X	C	A	E	S
E	V	O	S	S	Z	D	L	R	U	D
S	C	F	C	B	T	F	A	E	N	R
A	G	O	N	G	N	E	V	D	I	U
B	O	N	G	O	S	R	E	R	M	M
O	C	Y	M	B	A	L	S	U	I	O
V	L	N	O	Y	X	E	S	M	D	Z
W	O	O	D	B	L	O	C	K	H	F

Find the percussion instruments in the wordsearch.

Celeste
Snare Drum
Gong
Claves
Cow Bell
Chimes
Wood Block
Bass Drum
Cymbals
Bongos

Which instrument is the odd one out because it is NOT untuned percussion?

Answer the following questions about untuned percussion.

1. What is the main feature of untuned percussion instruments? _____

2. How are untuned percussion instruments usually played? _____

3. Name the two ways in which a percussionist can play cymbals in an orchestra. _____

4. How many years has the triangle been used in the orchestra? _____
5. Where did the tambourine originally come from? _____
6. Where do castanets originally come from? _____

TIMPANI / KETTLEDRUMS - Factsheet

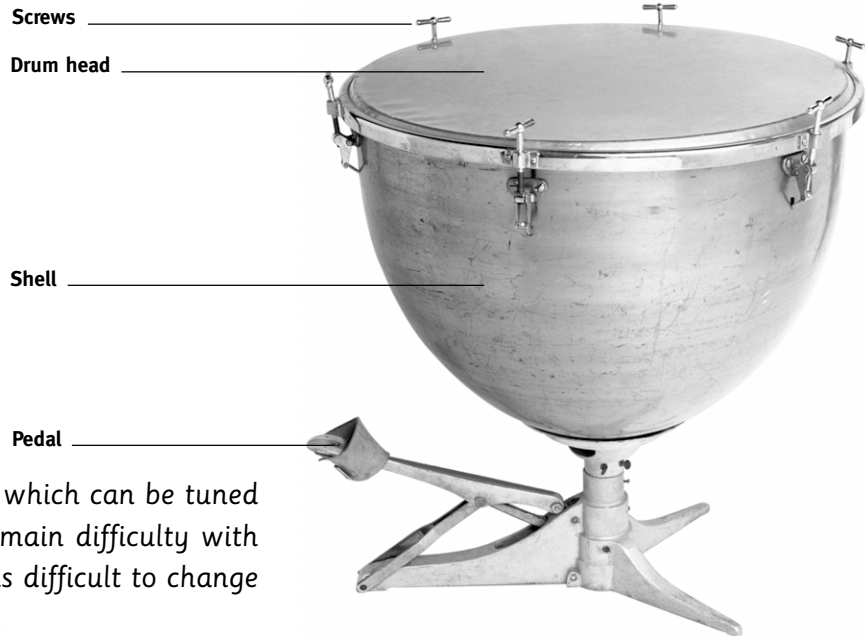

Timpani Drum

Timpani are large drums which can be tuned to different pitches. The main difficulty with timpani drums is that it is difficult to change the pitch of them quickly.

As with all drums the timpani drums have a skin or membrane which is stretched tightly across a frame. Tightening or loosening this membrane across the drumhead alters the pitch. By loosening the membrane the pitch will lower. In early timpani this was done using a series of keys which turned screws fitted

around the drum. This however was too time consuming and so in the nineteenth century a system was developed where a handle turned all the screw heads at once both evenly and more quickly.

The best timpani drums today use a pedal to shift the tension between several set points on a tuning gauge. However, hand screw timpani are still very popular and much cheaper!

Famous works for timpani:

Symphonie Fantastique (Thunderstorm) (Timpani)	Berlioz
Festival Overture (Timpani)	Smetna
Ruslan and Lyudmilla (Timpani)	Glinka

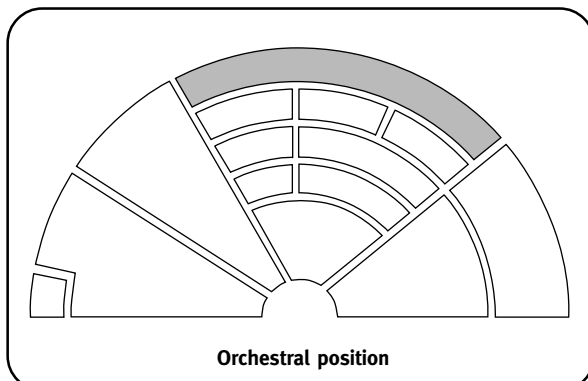

Orchestral position



Snare Drum

Other drums that are used in the orchestra are bass drums and snare drums, although neither of these are tuned percussion instruments like the timpani.

Name: _____

TIMPANI / KETTLEDRUMS - Worksheet

Label the diagram of the timpani drum.

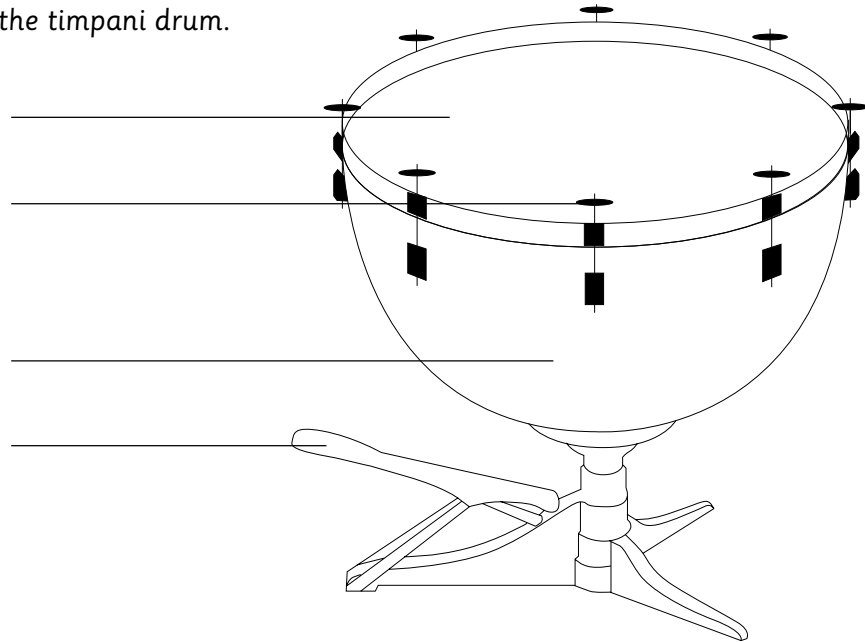

Answer true or false to the following statements about timpani drums.

1. Timpani drums are sometimes known as kettledrums? _____
2. Timpani drums are tuned percussion? _____
3. If a timpani player tightens the drumhead it makes the pitch of the notes lower? _____
4. In older timpani drums a series of keys was used to tighten the drumhead? _____
5. The best drums use a pedal to change the tension? _____
6. A famous piece which uses the timpani drums is *The Swan* by Saint-Saens? _____

Write a short paragraph about timpani drums below.

ORCHESTRAL PERCUSSION - Factsheet



Tambourine



Triangle

The percussion section of the orchestra varies enormously depending on which piece of music is being performed and in which period it was written. Up until the Romantic period the percussion section of the orchestra consisted only of the timpani or kettledrums. It was in the nineteenth century that composers really began to explore the possibilities of percussion instruments although in the eighteenth century some composers began to add cymbals and triangles to pieces.

Percussion instruments fall into two types - tuned and untuned. Tuned percussion instruments are capable of playing a tune or melody whereas untuned percussion can only provide effects or rhythmic ideas.

Famous works for percussion:

1812 Overture	Tchaikovsky
(Tubular Bells, Vibraphone & Wind Machine)	
Danse Macabre (Xylophone)	Saint-Saens
Sorcerer's Apprentice	Dukas
(Glockenspiel)	

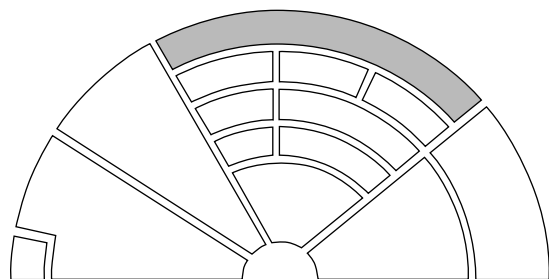

Orchestral position

Here are some tuned percussion instruments:

Orchestral Xylophone	Celeste
Orchestral Glockenspiel	Marimba
Tubular Bells	Timpani Drums

(Timpani can be tuned to different notes)

Untuned percussion instruments can include:

Wood Blocks	Triangles
Cymbals	Castanets
Whips	Claves
Gongs	Sleigh Bells
Cow Bells	Maracas
Snare Drum	Bass Drum

Sometimes composers ask for sounds like thunder, horses hooves or train whistles and so the percussion section has to be very versatile and inventive!

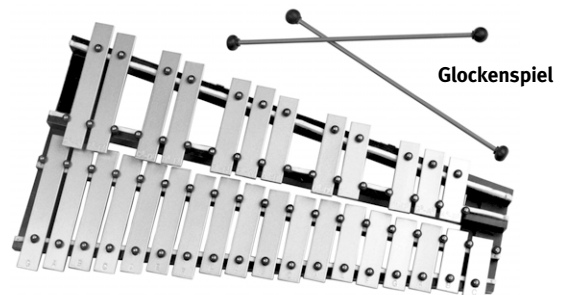

Glockenspiel

Famous percussionists

Evelyn Glennie

James Blades
Dave Hassel
Jimmy Holland

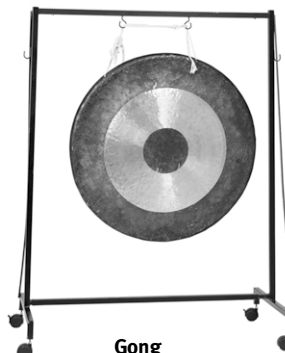

Gong



Timpani Drum

ORCHESTRAL PERCUSSION - Worksheet

Below are some tuned and untuned percussion instruments. Write the names of the instruments in the box they belong to.

Xylophone

Cow Bells

Celeste

Gongs

Glockenspiel

Claves

Sleigh Bells

Marimba

Tubular Bells

Cymbals

Timpani Drums

Wood Blocks

Triangles

Castanets

Maracas

Bass Drum

TUNED	UNTUNED

Identify the following instruments.

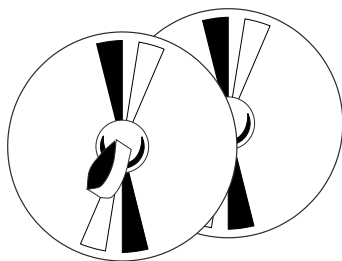

1. _____

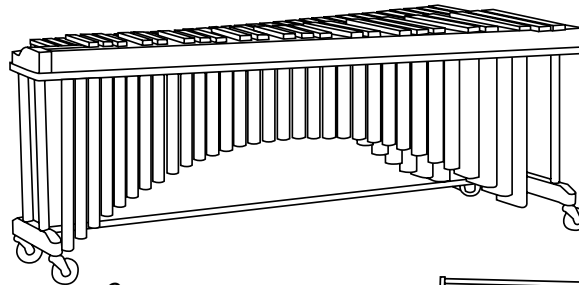

3. _____

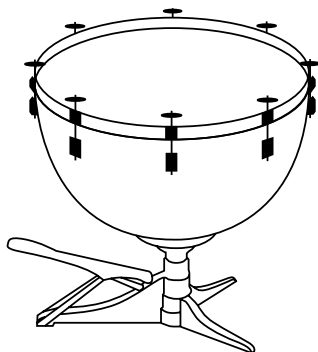

2. _____



4. _____

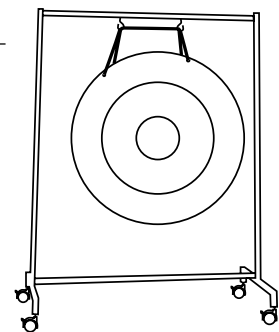

5. _____

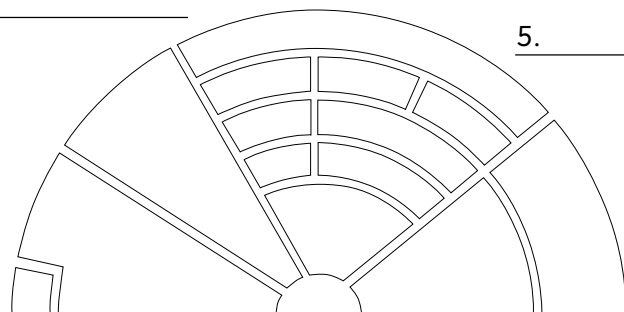

Here is a diagram of the layout of an orchestra. Shade in where the percussion section would sit.